

# General Specifications

## Model ZR22S and ZR202S Explosionproof Direct In Situ Zirconia Oxygen Analyzers

EXAXI

CE

GS 11M13A01-01E

### Overview

Two types are available explosionproof direct in situ zirconia oxygen analyzer. Model ZR22S/ZR402G is a separate type which consists of a ZR22S explosionproof probe and a ZR402G non-explosionproof converter. Model ZR202S is an integrated type which combines a probe and a converter.

Separate and integrated type Zirconia oxygen analyzers do not need a sampling device, and allow direct installation of the probe in the wall of a flue or furnace to measure the concentration of oxygen in the stack gas.

The converter displays the cell temperature and cell emf in addition to the oxygen concentration.

This analyzer is most suitable for monitoring combustion and controlling the low-oxygen combustion of various industrial furnaces in explosive atmosphere at petroleum refinery, petrochemical plant, and natural gas plant.



**ZR22S**  
Separate Type  
Explosionproof Probe

**ZR402G**  
General Purpose Type  
Converter



**ZR202S**  
Integrated Type  
Explosionproof Zirconia Oxygen Analyzer

### Features:

- The built-in heater assembly of the probe can be replaced on site, reducing maintenance costs.
- The probe uses a long-life, high-reliability Zirconia sensor.
- The separate type converter ZR402G incorporates a LCD touch-screen for ease of operation.
- The integrated type ZR202S integrates both probe and converter, to reduce wiring, piping, and installation costs. ZR202S uses an optical switch for ease of operation at the site.
- Remote maintenance using digital communications (HART) reduces maintenance costs. \*1

\*1: HART is a registered trademark of HART Communication Foundation.

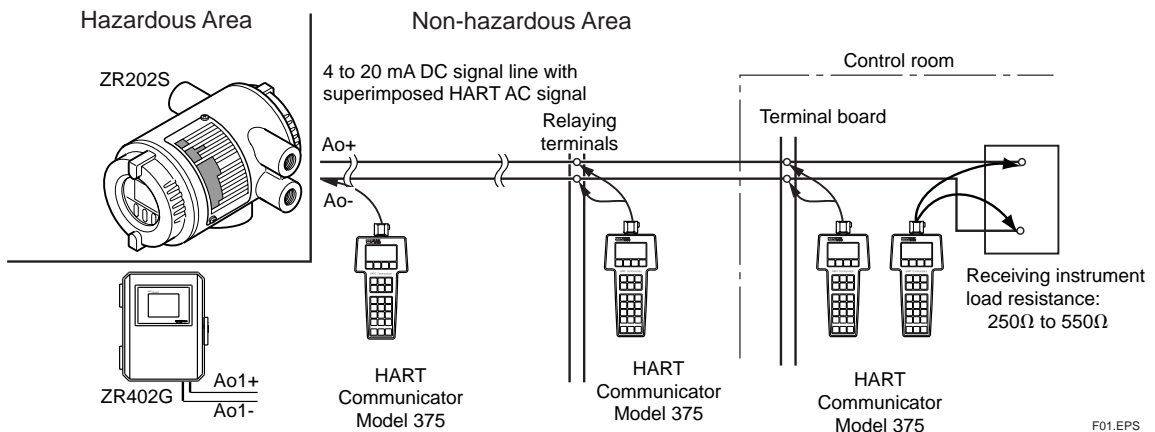

F01.EPS

## Basic System Configuration

### System configuration - Separate type Explosionproof

**Example 1**

- Automatic calibration system uses instrument air for reference gas.  
For the calibration gas, a standard gas cylinder may be used for more accurate calibration.
- Applications: Oxygen concentration monitoring and control in boilers.  
(for private and public power generation ) and in heating furnaces.

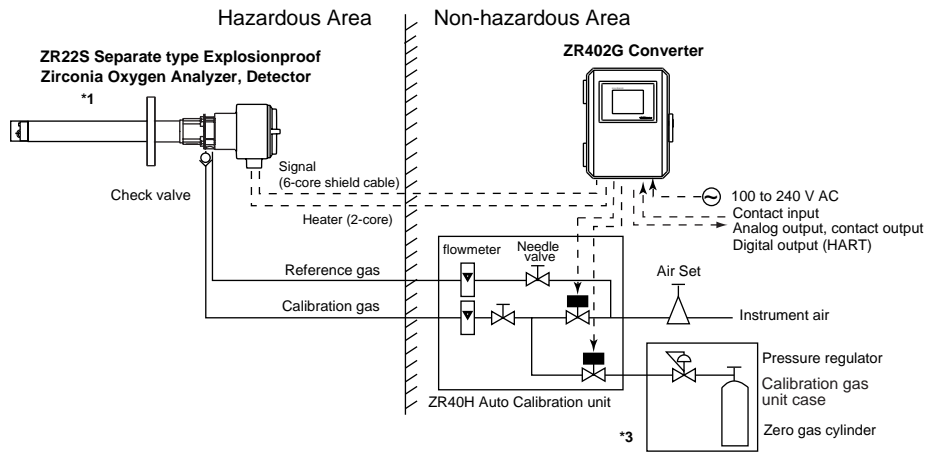

F02.EPS

### System configuration - Integrated type Explosionproof

**Example 1**

- For an integrated type as shown in the figure above.
- Applications: Oxygen concentration monitoring and control in boilers.  
(for private and public power generation)

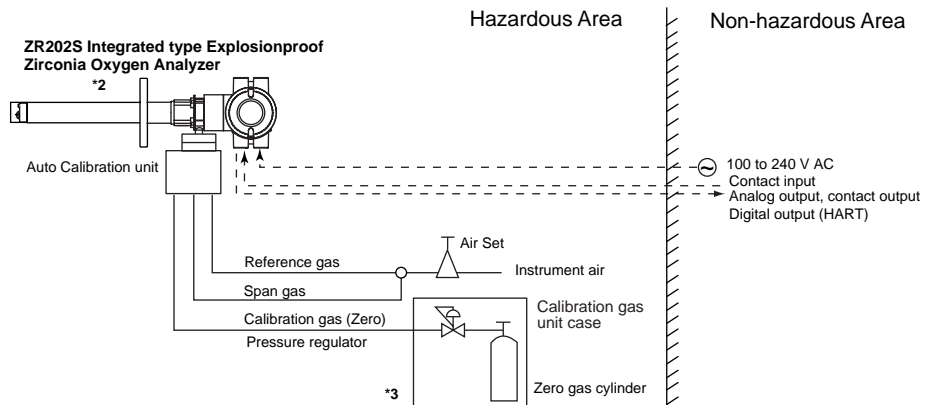

Note:  
The installation temperature limits range for integrated type analyzer is -20 to 55 °C.

F03.EPS

\*1 Shield cable:

Use shielded signal cables, and connect the shields to the FG terminal of the converter.

\*2 Select the desired probe from the Probe Configuration table on page 4.

\*3 When a zirconia oxygen analyzer is used, 100% N<sub>2</sub> gas cannot be used as the zero gas. Use approx. 1 vol% O<sub>2</sub> gas (N<sub>2</sub>-balanced).

## Basic System Configuration

### System configuration — Separate type Explosionproof

**Example 2**

- Instrument air is used as the reference gas.  
A standard gas cylinder can be used for the calibration gas for more accurate calibration.
- Application example: Oxygen concentration monitoring and control in boilers.  
(for private and public power generation) and in heating furnaces.

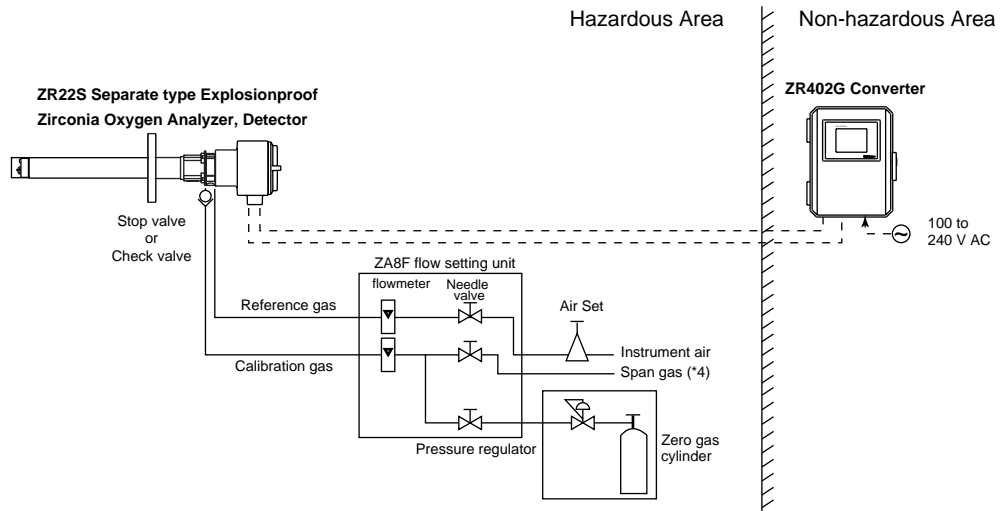

\*4 Calibration gas unit same as for zero gas.

F04.EPS

### System configuration — Integrated type Explosionproof

**Example 2**

- Instrument air is used as the reference gas.  
A standard gas cylinder can be used for the calibration gas for more accurate calibration.
- Application example: Oxygen concentration monitoring and control in boilers.  
(for private and public power generation)

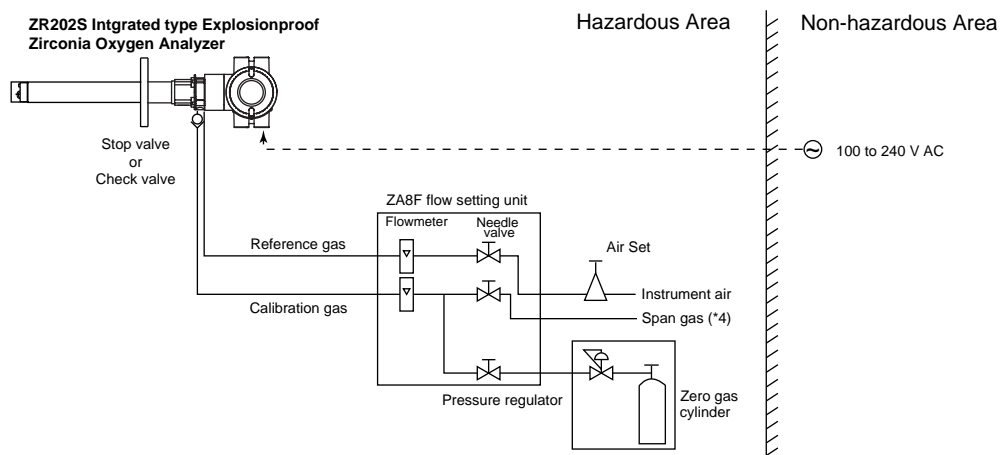

F06.EPS

**System Components**

System Components		Separate type		Integrated type	
		System config.		System config.	
		Ex.1	Ex.2	Ex.1	Ex.2
1	ZR22S Separate type Explosionproof Zirconia Oxygen Analyzers Detector	●	●		
2	ZR402G Separate type Zirconia Oxygen Analyzer, Converter(*1)	●	●		
3	ZR202S Integrated type Explosionproof Zirconia Oxygen Analyzers			●	●
4	ZO21P Adapter for High Temperature Probe of separate type Zirconia Oxygen Analyzer	○	○		
5	E7046EC, E7046EN Auxiliary Ejector for High Temperature Probe of separate type Oxygen Analyzer	○	○		
6	ZO21R Probe Protector for Zirconia Oxygen Analyzers	○	○	○	○
7	ZO21S Standard Gas Unit (*3)				
8	ZA8F Flow setting unit for manual calibration		●		●
9	ZR40H Automatic Calibration Unit for Separate type Analyzer	●			
10	Automatic Calibration Unit for Integrated type Analyzer (*2)			●	
11	L9852CB, G7016XH Stop Valve for Calibration-gas line		(●)		(●)
12	K9292DN, K9292DS Check Valve for Calibration-gas line	●	(●)		(●)
13	G7003XF/K9473XK, G7004XF/K9473XG Air Set	●	●	●	●
14	G7013XF, G7014XF Pressure Regulator for Gas Cylinder	●	●	●	●
15	ZR22A, ZR202A Heater Assembly for Spare Parts	○	○	○	○

- : Items required for the above system example
- : To be selected depending on each application. For details, refer to Chapter of Options.
- (●) : Select either
- (\*1) : When used as a high temperature humidity analyzer, specify /HS options.
- (\*2) : When Auto Calibration of (-A) or (-B) code is specified, Auto Calibration Unit is installed in ZR202S.
- (\*3) : Non CE mark

T01.EPS

**Detector Components**

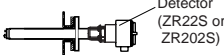
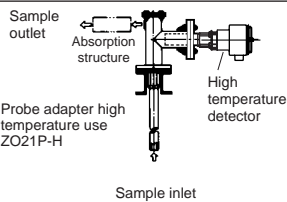
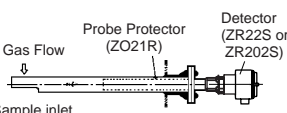
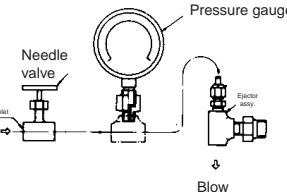
Process gas temperature 0 to 700°C				Process gas temperature 0 to 1400°C	
Mounting	Insertion length	General-use Probe	Application	High temperature detector	Application
Horizontal to vertical	2 m or less		Boiler Heating furnace		Heating furnace
			For pulverized coal boiler with gas flow velocity 10 m/s or more	<p>Temperature: Probe material SUS310S 800°C Probe material SIC 1400°C Mounting: Vertical downwards Insertion length: 1.0m, 1.5m When duct pressure is atmospheric or negative, attach air ejector. High temperature auxiliary ejector (E7046EC, E7046EN)</p> 	

F08.EPS

**Application Example:**

Separate and integrated type Zirconia Oxygen Analyzers

- Large, medium and small boilers (boilers for power generation: heavy oil, gas or coal)
- Various industrial furnaces (refinery process/iron manufacture heating furnace, coal kiln, and black liquid recovery boilers)  
For other applications, refer to TI 11M12A01-01E.
- May not be applicable corrosive gas such as ammonia and chlorine.

## ■ STANDARD SPECIFICATIONS

### General Specifications

Measurement Object: Oxygen concentration in combustion exhaust gas and mixed gas (excluding inflammable gases). May not be applicable corrosive gas such as ammonia and chlorine.

Measurement System: Zirconia system

Explosionproof Approval:

ZR22S-A (ATEX);

Applicable Standard: EN50014:1997  
+A1,+A2,EN50018:2000+A1,  
EN 50281-1-1:1998+A1

Certificate: KEMA 04ATEX2156

Type of Protection and Marking

Code: EEx d HB+H<sub>2</sub>

Group: II

Category: 2GD

Temperature Class: T2, T300°C

Enclosure: IP66

ZR22S-B (FM);

Applicable Standard: FM3600 1998,  
FM3615 1989, FM3810  
2005, ANSI/NEMA 250 1991

Explosionproof for Class I, Division  
1, Groups B, C and D

Dust-ignitionproof for Class II/III,  
Division 1, Groups E, F and  
G

Enclosure Rating: NEMA 4X

Temperature Class: T2

ZR22S-C (CSA);

Applicable Standard: C22.2 No.0-  
M1991, C22.2 No. 0.4-04,  
C22.2 No.0.5-1982, C22.2  
No.25-1966, C22.2 No.30-  
M1986, C22.2 No.94-M91,  
C22.2-No.61010-1-04

Certificate: 1649642

Explosionproof for Class I, Division  
1, Groups B, C and D

Dust-ignitionproof for Class II/III,  
Division 1, Groups E, F and  
G

Enclosure: Type 4X

Temperature Class: T2

ZR22S-D (IECEX);

IECEX flameproof type

Applicable Standard: IEC 60079-  
0:2004, IEC 60079-1:2003,  
IEC 61241-0:2004, IEC  
61241-1:2004

Certificate: IECEX KEM 06.0006

Ex d IIB+H<sub>2</sub> T2

Enclosure: IP66

IECEX type of protection "Dust"

Ex tD A21 IP66 T300°C

Enclosure: IP66

ZR202S-A (ATEX);

Applicable Standard: EN50014:1997  
+A1,+A2,EN50018:2000,  
EN 50281-1-1:1998

Certificate: KEMA 04ATEX2156

Type of Protection and Marking

Code: EEx d HB+H<sub>2</sub>

Group: II

Category: 2GD

Temperature Class: T2, T300°C

Enclosure: IP66

ZR202S-B (FM);

Applicable Standard: FM3600 1998,  
FM3615 1989, FM3810

2005, ANSI/ASME 250 1991

Explosionproof for Class I, Division  
1, Groups B, C and D

Dust-ignitionproof for Class II/III,  
Division 1, Groups E, F and  
G

Enclosure Rating: NEMA 4X

Temperature Class: T2

ZR202S-C (CSA);

Applicable Standard: C22.2 No.0-  
M1991, C22.2 No. 0.4-04,  
C22.2 No.0.5-1982, C22.2  
No.25-1966, C22.2 No.30-  
M1986, C22.2 No.94-M91,  
C22.2-No.61010-1-04

Certificate: 1649642

Explosionproof for Class I, Division  
1, Groups B, C and D

Dust-ignitionproof for Class II/III,  
Division 1, Groups E, F and  
G

Enclosure: Type 4X

Temperature Class: T2

ZR202S-D (IECEX);

IECEX flameproof type

Applicable Standard: IEC 60079-  
0:2004, IEC 60079-1:2003,  
IEC 61241-0:2004, IEC  
61241-1:2004

Certificate: IECEX KEM 06.0006

Ex d IIB+H<sub>2</sub> T2

Enclosure: IP66

IECEX type of protection "Dust"

Ex tD A21 IP66 T300°C

Enclosure: IP66

Oxygen Concentration: 0.01 to 100 vol% O<sub>2</sub>

Output Signal: 4 to 20 mA DC (maximum load resistance  
550Ω)

Measurement Range: Any setting in the range of 0 to 5  
through 0 to 100 vol% O<sub>2</sub> (in 1 vol% O<sub>2</sub>), or  
partial range

Digital Communication (HART): 250 to 550Ω, depending  
on number of field devices connected to the  
loop (multi-drop mode).

Note: HART is a registered trademark of the HART  
Communication Foundation.

Display Range: 0 to 100 vol% O<sub>2</sub>

Warm-up Time: Approx. 20 min.

Repeatability:

± 0.5% Maximum value of set range. (less  
than 0 to 25 vol% O<sub>2</sub> range)  
± 1 % Maximum value of set range.  
(0 to 25 vol% O<sub>2</sub> or more and up to 0 to 100  
vol% O<sub>2</sub> range)

Linearity:

(Excluding standard gas tolerance)  
(Use oxygen of known concentration (with in  
the measuring range) as the zero and span  
calibration gases.)  
± 1% Maximum value of set range.; less  
than 0 to 25 vol% O<sub>2</sub> range  
(Sample gas pressure: within ± 4.9 kPa)  
± 3% Maximum value of set range.; 0 to 25  
vol% O<sub>2</sub> or more and less than 0 to 50  
vol% O<sub>2</sub> range  
(Sample gas pressure: within ± 0.49 kPa)  
± 5% Maximum value of set range.; 0 to 50  
vol% O<sub>2</sub> or more and up to 0 to 100 vol% O<sub>2</sub>  
range  
(Sample gas pressure: within ± 0.49 kPa)

Drift: (Excluding the first two weeks in use)  
Both zero and span  $\pm 2\%$  Maximum value  
of set range/month

Response Time:  
Response of 90% within 5 seconds.  
(Measured after gas is introduced from  
calibration gas inlet and analog output starts  
changing.)

### 1. ZR22S Separate type Explosionproof Zirconia Oxygen Analyzer, Detector

Sample Gas Temperature: 0 to 700°C (Probe only)  
It is necessary to mount the cell using  
Inconel cell-bolts when the temperature is  
greater than 600°C.  
700 to 1400°C (with High Temperature  
Probe Adapter)  
For high-temperature sample gas, apply  
0.15m length probe and High Temperature  
Probe Adapter ZO21P-H.

Sample Gas Pressure: -5 to +5 kPa  
For 0.15m probe, -0.5 to +5 kPa.  
No pressure fluctuation in the furnace should  
be allowed.

Probe Length: 0.15, 0.4, 0.7, 1.0, 1.5, 2.0 m  
Probe Material: SUS 316 (JIS)  
Ambient Temperature: -20 to +60°C (-20 to +150°C on  
the terminal box surface)

Reference Air System: Instrument Air  
Instrument Air System: Pressure; 50 kPa + the pressure  
inside the furnace (It is recommended to use  
air which has been dehumidified by cooling  
to dew point -20°C or less, and dust or oil  
mist removed.)  
Consumption; Approx. 1NI/min

Material in Contact with Gas: SUS 316 (JIS), Zirconia,  
SUS 304 (JIS) (flange), Hastelloy B, (Inconel  
600, 601)

Construction: Heater and thermocouple replaceable  
construction.  
Equivalent to NEMA 4X/IP66.(Achieved  
when pipes are installed at calibration gas  
and reference air inlets and pipe is installed  
so that reference air can be exhausted to  
clean atmosphere. Excluding probe top. And  
achieved when the cable entry is completely  
sealed with a cable gland.)

Terminal Box Case: Material; Aluminium alloy  
Terminal Box Paint Color:  
Case: Mint green (Munsell 5.6BG3.3/2.9)  
Cover: Mint green (Munsell 5.6BG3.3/2.9)

Finish: Polyurethane corrosion-resistance coating  
Gas Connection: Rc 1/4 or 1/4 NPT  
Wiring Connection:  
ATEX; M20 by 1.5 mm or 1/2 NPT select  
one type (2 pieces)  
FM; 1/2 NPT (2 pieces)  
CSA; 1/2 NPT (2 pieces)  
IECEX; M20 by 1.5 mm or 1/2 NPT select  
one type (2 pieces)

Installation: Flange mounting  
Probe Mounting Angle:  
Installing at angles from horizontal to  
vertical downward is possible.

Weight:  
Insertion length of 0.4 m: approx. 13 kg (ANSI 150 4)  
Insertion length of 0.7 m: approx. 14 kg (ANSI 150 4)  
Insertion length of 1.0 m: approx. 15 kg (ANSI 150 4)  
Insertion length of 1.5 m: approx. 17 kg (ANSI 150 4)  
Insertion length of 2.0 m: approx. 19 kg (ANSI 150 4)  
Available Converter: ZR402G, AV550G

### 2. ZR402G Separate type General purpose Zirconia Oxygen Analyzer, Converter

Converter must not be located in hazardous area.  
Operated using an LCD touchscreen on the converter.  
Display: LCD display of size 320 by 240 dot with  
touchscreen.  
Output Signal: 4 to 20 mA DC, two points (maximum  
load resistance 550Ω)  
Contact Output Signal: four points (one is fail-safe,  
normally open)  
Contact Input: two points  
Auto-calibration Output: Two points (for dedicated auto-  
calibration unit)  
Ambient Temperature: -20 to +55°C  
Storage Temperature: -30 to +70°C  
Humidity Range: 0 to 95% RH (non-condensing)  
Installation Altitude: 2000 m or less  
Category based on IEC 1010: II (Note)  
Pollution degree based on IEC 1010: 2 (Note)  
Note: Installation category, called over-voltage  
category, specifies impulse withstand voltage.  
Category II is for electrical equipment.  
Pollution degree indicates the degree of existence  
of solid, liquid, gas or other inclusions which may  
reduce dielectric strength. Degree 2 is the normal  
indoor environment.

Power Supply Voltage: Ratings; 100 to 240 V AC  
Acceptable range; 85 to 264 V AC  
Power Supply Frequency: Ratings; 50/60 Hz  
Acceptable range; 45 to 66 Hz  
Power Consumption: Max. 300 W, approx. 100 W for  
ordinary use.

Safety and EMC conforming standards  
Safety: Conforms to EN 61010-1  
CSA C22.2 No.61010-1 certified  
UL 61010-1 certified  
EMC: Conforms to EN 61326 Class A  
EN55011 Class A, Group 1  
EN61000-3-2

Maximum Distance between Probe and Converter:  
Conductor two-way resistance must be 10 Ω  
or less (when a 1.25 mm<sup>2</sup> cable or equiva-  
lent is used, 300 m or less.

Construction: Outdoor installation, equivalent to NEMA  
4X/IP66 (with conduit holes completely  
sealed with a cable gland)

Wiring Connection: G1/2, Pg13.5, M20 by 1.5 mm, 1/2  
NPT, eight holes  
Installation: Panel, wall or 2-inch pipe mounting  
Case: Aluminum alloy  
Paint Color: Door: Silver gray (Munsell 3.2PB7.4/1.2)  
Case: Silver gray (Munsell 3.2PB7.4/1.2)  
Finish: Polyurethane corrosion-resistance coating  
Weight: Approx. 6 kg

#### Functions

Display Functions:  
Value Display; Displays values of the measured  
oxygen concentration, etc  
Graph Display; Displays trends of measured oxygen  
concentration

- Data Display; Displays various useful data for maintenance, such as cell temperature, reference junction temperature, maximum/minimum oxygen concentration, or the like
- Status Message; Indicates an alarm or error occurrence with flashing of the corresponding icon. Indicates status such as warming-up, calibrating, or the like by icons.
- Alarm, Error Display; Displays alarms such as "Abnormal oxygen concentration" or errors such as "Abnormal cell e.m.f." when any such status occurs.
- Calibration Functions:
- Auto-Calibration; Requires the Auto-calibration Unit. It calibrates automatically at specified intervals.
  - Semi-auto Calibration; Requires the Auto-calibration Unit. Input calibration direction on the touchscreen or contact, then it calibrates automatically afterwards.
  - Manual Calibration; Calibration with opening/closing the valve of calibration gas in operation interactively with an LCD touchscreen.
- Blowback Function:
- Output through the contact in the set period and time. Auto/semi-auto selectable.
- Maintenance Functions:
- Can operate updated data settings in daily operation and checking. Display data settings, calibration data settings, blowback data settings, current output loop check, input/output contact check.
- Setup Functions:
- Initial settings suit for the plant conditions when installing the converter. Equipment settings, current output data settings, alarm data settings, contact data settings, other settings.
- Self-diagnosis:
- This function diagnoses conditions of the converter or the probe and indicates when any abnormal condition occurs.
- Password Functions:
- Enter your password to operate the analyzer excepting data display. Individual passwords can be set for maintenance and setup.
- Display and setting content:
- Measuring related items: Oxygen concentration (vol% O<sub>2</sub>), Output current value (mA), air ratio, moisture quantity (in hot gases) (vol% H<sub>2</sub>O)
- Display Items: Cell temperature (°C), thermocouple reference junction temperature (°C), maximum/minimum/average oxygen concentration (vol% O<sub>2</sub>), cell e.m.f. (mV), cell internal resistance (Ω), cell condition (in four grades), heater on-time rate (%), calibration record (ten times), time (year/month/day, hour/minute)
- Calibration Setting Items: Span gas concentration (vol% O<sub>2</sub>), zero-gas concentration (vol% O<sub>2</sub>), calibration mode (auto, semi-auto, manual), calibration type and method (zero-span calibration, zero calibration only, span calibration only), stabilization time (min.sec), calibration time (min.sec), calibration period (day/hour), starting time (year/month/day, hour/minute)
- Equipment Related Items: Measuring gas selection
- Output Related Items: Analog output/output mode selection, output conditions when warming-up/maintenance/calibrating (during blowback)/abnormal, 4 mA/20 mA point oxygen concentration (vol% O<sub>2</sub>), time constant, preset values when warming-up/maintenance/calibrating during blowback abnormal, output preset values on abnormal
- Alarm Related Items: Oxygen concentration high-alarm/high-high alarm limit values (vol% O<sub>2</sub>), Oxygen concentration low-alarm/low-low alarm limit values (vol% O<sub>2</sub>), Oxygen concentration alarm hysteresis (vol% O<sub>2</sub>), Oxygen concentration alarm detection, alarm delay (seconds)
- Contact Related Items: Selection of contact input 1 and 2, selection of contact output 1 to 4 (abnormal, high-high alarm, high-alarm, low-alarm, low-low alarm, maintenance, calibrating, range switching, warming-up, calibration-gas pressure decrease, temperature high-alarm, blowback, flameout gas detection)
- Converter Output: Two points mA analog output (4 to 20 mA DC (maximum load resistance of 550 Ω)) and one mA digital output point (HART) (minimum load resistance of 250Ω).  
Range: any setting between 0 to 5 through 0 to 100 vol% O<sub>2</sub> in 1 vol% O<sub>2</sub>, or partial range is available (Maximum range value/minimum range value 1.3 or more)  
For the log output, the minimum range value is fixed at 0.1 vol% O<sub>2</sub>.  
4 to 20 mA DC linear or log can be selected.  
Input/output isolation  
Output damping: 0 to 255 seconds.  
Hold/non-hold selection, preset value setting possible with hold
- Contact Output: Four points, contact capacity 30 V DC 3 A, 250 V AC 3 A (resistive load)  
Three of the output points can be selected to either normally energized or normally de-energized status.  
Delayed functions (0 to 255 seconds) and hysteresis function (0 to 9.9 vol%O<sub>2</sub> can be added to high/low alarms.  
The following functions are programmable for contact outputs.

(1) Abnormal, (2) High-high alarm, (3) High-alarm, (4) Low-low alarm, (5) Low-alarm, (6) Maintenance, (7) Calibration, (8) Range switching answer-back, (9) Warm-up, (10) Calibration-gas pressure decrease (answer-back of contact input), (11) Temperature high-alarm, (12) Blowback start, (13) Flameout gas detection (answerback of contact input), (14) Calibration coefficient alarm, (15) Startup power stabilization timeout alarm  
 Contact output 4 is set to normally operated, fixed error status.

Contact Input: Two points, contact input The following functions are programmable for contact inputs:

(1) Calibration-gas pressure decrease alarm, (2) Range switching, (3) External calibration start, (4) Process alarm (if this signal is received, the heater power turns off), (5) Blow-back start

Contact capacity: Off-state leakage current: 3 mA or less  
 Self-diagnosis: Abnormal cell, abnormal cell temperature (low/high), abnormal calibration, defective A/D converter, defective digital circuit

Calibration: Method; zero/span calibration  
 Calibration mode; automatic, semi-automatic and manual (All are operated interactively with an LCD touchscreen). Either zero or span can be skipped.

Zero calibration-gas concentration setting range: 0.3 to 100 vol% O<sub>2</sub> (0.01 vol% O<sub>2</sub> in smallest units).

Span calibration-gas concentration setting range: 4.5 to 100 vol% O<sub>2</sub> (0.01 vol% O<sub>2</sub> in smallest units).

Use nitrogen-balanced mixed gas containing 10 vol% O<sub>2</sub> scale of oxygen, and 80 to 100 vol% O<sub>2</sub> scale of oxygen for standard zero-gas and standard span-gas respectively.

Calibration period; date/time setting: maximum 255 days

### 3. ZR202S Integrated type Explosionproof Zirconia Oxygen Analyzer

Display: 6-digit LCD

Switch: Three optical switches

Output Signal: 4 to 20 mA DC, one point (maximum load resistance 550Ω)

Digital Communication (HART): 250 to 550Ω, depending on quantity of field devices connected to the loop (multi-drop mode).

Note: HART is a registered trademark of the HART Communication Foundation.

Contact Output Signal: Two points (one is fail-safe, normally open)

Contact Input Signal: Two points

Sample Gas Temperature: 0 to 700°C

It is necessary to mount the cell using Inconel cell-bolts when the temperature measures more than 600°C.

High-temperature service – greater than 700°C – is not available.

Sample Gas Pressure: - 5 to + 5 kPa

No pressure fluctuation in the furnace should be allowed.

Probe Length: 0.4, 0.7, 1.0, 1.5, 2.0

Probe Material: SUS 316 (JIS)

Ambient Temperature: -20 to +55°C (- 5 to +70°C on the case surface)

Storage Temperature: -30 to +70°C

Humidity Range: 0 to 95 %RH (non-condensing)

Installation Altitude: 2000 m or less

Category based on IEC 1010: II (Note)

Pollution degree based on IEC 1010: 2 (Note)

Note: Installation category, called over-voltage category, specifies impulse withstand voltage.

Category II is for electrical equipment.

Pollution degree indicates the degree of existence of solid, liquid, gas or other inclusions which may reduce dielectric strength. Degree 2 is the normal indoor environment.

Power Supply Voltage: Ratings; 100 to 240 V AC

Acceptable range; 85 to 264 V AC

Power Supply Frequency: Ratings; 50/60 Hz

Acceptable range; 45 to 66 Hz

Power Consumption: Max. 300 W, approx. 100 W for ordinary use.

Safety and EMC conforming standards

Safety: EN61010-1

CSA C22.2 No.61010-1

UL61010-1

EMC: EN 61326 Class A

EN 55011 Class A Group 1

EN 61000-3-2

AS/NZS CISPR 11

Reference Air System: Instrument Air

Instrument Air System:

Pressure; 50 kPa + the pressure inside the furnace 150 kPa + the pressure inside the furnace with auto calibration unit. (It is recommended to use air which is dehumidified by cooling to dew point -20°C or less, and filtering to remove dust or oil mist.)

Consumption; Approx. 1.5NI/min

Material in Contact with Gas: SUS 316 (JIS), Zirconia, SUS 304 (JIS) (flange), Hastelloy B, (Inconel 600, 601)

Construction: Heater and thermocouple replaceable construction.

NEMA 4X/IP66

(Achieved when pipes are installed at calibration gas and reference air inlet and exhaust pipe is installed so that reference air can be exhausted to clean atmosphere. Excluding probe top.)

(Achieved when the cable entry is completely sealed with a cable gland.)

Gas Connection: Rc 1/4 or 1/4 NPT

Wiring Connection: ATEX: M20 by 1.5mm, 1/2 NPT select one type (4 pieces)

FM: 1/2 NPT (4 pieces),

CSA: 1/2 NPT (4 pieces),

IECEX: M20 by 1.5mm or 1/2 NPT select one type (4 pieces)

Installation: Flange mounting

**Probe Mounting Angle:**

Horizontal to vertically downward.  
Installing at angles from horizontal to vertical downward is available.

Case: Aluminum alloy

Paint Color: Cover; Mint green (Munsell 5.6BG3.3/2.9)

Case: Mint green (Munsell 5.6BG3.3/2.9)

Finish: Polyurethane corrosion-resistance coating

**Weight:**

Insertion length of 0.4 m: approx. 15 kg (ANSI 150 4)

Insertion length of 0.7 m: approx. 16 kg (ANSI 150 4)

Insertion length of 1.0 m: approx. 17 kg (ANSI 150 4)

Insertion length of 1.5 m: approx. 19 kg (ANSI 150 4)

Insertion length of 2.0 m: approx. 21 kg (ANSI 150 4)

**Functions**

Display Function: Displays values of the measured oxygen concentration, etc.

Alarm, Error Display: Displays alarms such as "AL-06" or errors such as "Err -01" when any such status occurs.

**Calibration Functions:**

Auto-calibration; Requires the Auto-calibration Unit. It calibrates automatically at specified intervals.

Semi-auto Calibration; Requires the Auto-calibration Unit. Input calibration start signal by optical switch or contact, then it calibrates automatically afterwards.

Manual Calibration; Calibration with opening/closing the valve of calibration gas in operation interactively with the optical switch.

**Maintenance Functions:**

Can operate updated data settings in daily operation and checking. Display data settings, calibration data settings, test settings (current output loop check, input/output contact check).

**Setup Functions:**

Initial settings suit for the plant conditions when installing the converter. Current output data settings, alarm data settings, contact data settings, other settings.

**Display and setting content:**

Display Related Items: Oxygen concentration (vol% O<sub>2</sub>), Output current value (mA), air ratio, moisture quantity (in hot gases) (vol% H<sub>2</sub>O), Cell temperature (°C), thermocouple reference junction temperature (°C), maximum/minimum/average oxygen concentration (vol% O<sub>2</sub>), cell e.m.f. (mV), cell internal resistance (Ω), cell condition (in four grades), heater on-time rate (%), calibration record (ten times), time (year/month/day/hour/minute)

Calibration Setting Items: Span gas concentration (vol% O<sub>2</sub>), zero-gas concentration (vol% O<sub>2</sub>), calibration mode (auto, semi-auto, manual), calibration type and method (zero-span calibration, zero calibration only, span calibration only), stabilization time (min.sec), calibration time (min.sec), calibration period (day/hour), starting time (year/month/day/hour/minute)

**Output Related Items: Analog output/output mode**

selection, output conditions when warming-up/maintenance/calibrating/abnormal, 4 mA/20 mA point oxygen concentration (vol% O<sub>2</sub>), time constant, preset values when warming-up/maintenance/calibrating/abnormal, output preset values on abnormal

**Alarm Related Items: Oxygen concentration high-**

alarm/high-high alarm limit values (vol% O<sub>2</sub>), Oxygen concentration low-alarm/low-low alarm limit values (vol% O<sub>2</sub>), Oxygen concentration alarm hysteresis (vol% O<sub>2</sub>), Oxygen concentration alarm detection, alarm delay (seconds)

**Contact Related Items: Selection of contact input 1**

and 2, selection of contact output 1 and 2 (abnormal, high-high alarm, high-alarm, low-alarm, low-low alarm, maintenance, calibrating, range switching, warming-up, calibration-gas pressure decrease, flameout gas detection (answerback of contact input))

**Converter Output: One mA analog output point (4 to 20**

mA DC (maximum load resistance of 550Ω)) with mA digital output point (HART) (minimum load resistance of 250Ω).

Range: any setting between 0 to 5 through 0 to 100 vol% O<sub>2</sub> in 1 vol% O<sub>2</sub>, and partial range is available (Maximum range value/minimum range value 1.3 or more)

For the log output, the minimum range value is fixed at 0.1 vol% O<sub>2</sub>.

4 to 20 mA DC linear or log can be selected.

Input/output isolation

Output damping: 0 to 255 seconds.

Hold/non-hold selection, preset value setting possible with hold.

**Contact Output: Two points, contact capacity 30 V DC**

3 A, 250 V AC 3 A (resistive load)

One of the output points can be selected to either normally energized or normally de-energized status.

Delayed functions (0 to 255 seconds) and hysteresis function (0 to 9.9 vol% O<sub>2</sub>) can be added to high/low-alarms.

The following functions are programmable for contact outputs.

(1) Abnormal, (2) High-high alarm, (3) High-alarm, (4) Low-low alarm, (5) Low-alarm, (6) Maintenance, (7) Calibration, (8) Range switching answer-back, (9) Warm-up, (10) Calibration-gas pressure decrease (answerback of contact input), (11) Flameout gas detection (answerback of contact input).

Contact output 2 is set to normally operated, fixed error status.

- Contact Input: Two points, voltage-free contacts  
The following functions are programmable for contact inputs:  
(1) Calibration-gas pressure decrease alarm, (2) Range switching (switched range is fixed), (3) External calibration start, (4) Process alarm (if this signal is received, the heater power turns off)
- Self-diagnosis: Abnormal cell, abnormal cell temperature (low/high), abnormal calibration, A/D converter abnormal, digital circuit abnormal
- Calibration: Method; zero/span calibration  
Calibration mode; automatic, semi-automatic and manual (All are operated using optical switches). Either zero or span can be skipped.  
Zero-calibration gas concentration setting range: 0.3 to 100 vol% O<sub>2</sub> (in 0.01 vol% O<sub>2</sub>).  
Span-calibration gas concentration setting range: 4.5 to 100 vol% O<sub>2</sub> (in 0.01 vol% O<sub>2</sub>).  
Use nitrogen-balanced mixed gas containing 10 vol% O<sub>2</sub> scale of oxygen for standard zero-gas, and 80 to 100 vol% O<sub>2</sub> scale of oxygen for standard span-gas.  
Calibration period; date/time setting: maximum 255 days

#### 4. ZO21P-H High Temperature Probe Adapter

Measuring O<sub>2</sub> in the high temperature gases (exceeds 700 °C) requires the ZR22S of 0.15m length and a high-temperature probe adapter.

- Sample gas temperature: 0 to 1400°C (when using SiC probe)  
0 to 800°C (when using SUS 310S probe adapter)
- Sample gas pressure: -0.5 to + 5 kPa. When using in the range of 0 to 25 vol% O<sub>2</sub> or more, the sample gas pressure should be in the range of -0.5 to +0.5 kPa. (Where the sample gas pressure for the high-temperature probe is negative, an auxiliary ejector is necessary.)
- Insertion length: 1 m, 1.5 m  
Material in Contact with Gas: SUS 316 (JIS), Zirconia, SiC or SUS 310S, SUS 304 (JIS) (flange)  
Probe Material: SiC, SUS 310S (JIS)  
Installation: Flange mounting (FF type or RF type)  
Probe Mounting Angle: Vertically downward within ±5°  
Where the probe material is SUS 310S, horizontal mounting is available.
- Construction: Non explosion-proof. Rainproof construction
- Weight: Insertion length of 1.0 m: approx. 6.5 kg (JIS) / approx. 8.5 kg (ANSI)  
Insertion length of 1.5m: approx. 7.5 kg (JIS) / approx. 9.5 kg (ANSI)

#### 5. E7046EC/E7046EN Auxiliary ejector

For use in cases where pressure of sample gas for high temperature detector is negative.

#### 5.1 Ejector Assembly

- Ejector Inlet Air Pressure: 29 to 68 kPa G  
Air Consumption: Approx. 30 to 40 l/min  
Suction gas flow rate: 3 to 7 l/min  
Connection: E7046EC Rc1/4 or E7046EN 1/4 NPT, SUS304 (JIS)  
Tube Connection: (∅ 6/∅ 4 or 1/4 inch copper tube or stainless tube)

#### 5.2 Pressure Gauge Assembly

- Pressure Gauge  
Type: JIS B7505, A1.5U3/8 x75  
Material in Contact with Gas: SUS316 (JIS)  
Case Material: Aluminum alloy (Paint color; black)  
Scale: 0 to 100 kPa G  
Bushing (G3/8 x Rc1/4 or 1/4NPT, SUS304 (JIS))

#### 5.3 Needle Valve

- Connection: Rc1/4 or 1/4NPT  
Material: SUS316 (JIS)  
(Note) Pipes and connectors are not provided.

#### 6. ZO21R Probe Protector

Used when sample gas flow velocity is approx. 10m/sec or more and dust particles wears the detector in cases such as pulverized coal boiler of fluidized bed furnace (or burner) to protect the detector from wearing by dust particles.

- Insertion Length: 1.05 m  
Flange: JIS 5K 65A FF equivalent. ANSI CLASS 150-4-FF (without serration) equivalent or DIN PN10-DN50-A equivalent. However, flange thickness is different.  
Material: SUS316 (JIS), SUS304 (JIS) (Flange)  
Weight: 1.05 m; Approx. 6/10/8.5 kg (JIS/ANSI/DIN),  
Installation: Bolts, nuts, and washers are provided for detector, probe adapter and process-side flange.

#### 7. ZO21S Standard Gas Unit (\*)

- Standard Gas Unit must not be located in hazardous area.
- Function: Portable unit for calibration gas supply consisting of span gas (air) pump, zero gas cylinder with sealed inlet, flow rate checker and flow rate needle valve.
- Sealed Zero Gas Cylinders (6 provided): E7050BA  
Capacity: 1 l  
Filled pressure: Approx. 686 kPa G (at 35 °C)  
Composition: 0.95 to 1.0 vol% O<sub>2</sub>+N<sub>2</sub> balance  
Power Supply: 100, 110, 115, 200, 220, 240V AC±10%, 50/60 Hz  
Power Consumption: Max.5 VA  
Paint Color: Mainframe; Munsell 2.0 GY3.1/0.5 equivalent  
Cover; Munsell 2.8 GY6.4/0.9 equivalent  
Weight: Approx. 3 kg  
(\* Non CE Mark.

#### 8. ZA8F Flow Setting Unit

Used when instrument air is provided.

This unit controls flow rates of calibration gas and reference gas and consists of flowmeter

and flow rate control valve.

- Flowmeter: Calibration gas; 0.1 to 1.0 l/min. Reference air; 0.1 to 1.0 l/min.
- Construction: Dust-proof and rainproof construction
- Case Material: SPCC (Cold rolled steel sheet)
- Painting: Baked epoxy resin, Dark-green (Munsell 2.0 GY 3.1/0.5 or equivalent)
- Tube Connections: Rc1/4 or 1/4 NPT
- Reference Air pressure: Clean air supply of measured gas pressure plus approx. 50 kPa G measured gas pressure plus approx. 150kPa (pressure rating is 70 to 100 kPa) when a check valve is used (pressure at inlet of the auto-calibration unit)
- Air Consumption: Approx. 1.5 l/min
- Weight: Approx. 2.3 kg

**9. ZR40H Auto-calibration Unit for Separate type Analyzer**

Auto-calibration Unit must be located in Non-hazardous area.

Used when auto calibration is required for the separate type and instrument air is provided. The solenoid valves are provided as standard.

- Construction: Dust-proof and rainproof construction: NEMA 4X/IP67 - only for case coating solenoid valve, not flowmeter (excluding flowmeter)
- Mounting: 2-inch pipe or wall mounting, no vibration
- Materials: Body: Aluminum alloy, Piping: SUS316 (JIS), SUS304 (JIS), Flowmeter: MA (Methacrylate resin) Bracket : SUS304 (JIS)
- Finish: Polyurethane corrosion-resistance coating, Mint green (Munsell 5.6BG3.3/2.9)
- Piping Connection: Refer to Model and Suffix Codes
- Power Supply: 24V DC (from ZR402G), Power consumption: Approx. 1.3 W
- Reference Air Pressure: Sample gas pressure + Approx. 150 kPa (Pressure at inlet of auto-calibration unit)
- Air Consumption: Approx. 1.5 l/min
- Weight: Approx. 3.5 kg
- Ambient Temperature: -20 to +55°C, no condensing and freezing
- Ambient Humidity: 0 to 95%RH
- Storage Temperature: -30 to +65°C

**10. Automatic Calibration Unit for Integrated type Analyzer**

When Auto Calibration of (-A) or (-B) code is specified, Auto Calibration Unit is installed in ZR202S.

Only Auto Calibration Unit is not available.

**11. L9852CB/G7016XH Stop Valve**

The stop valve and the nipple are mounted on the calibration gas line.

The nipple is used to connect the stop valve. They are attached when the suffix code (/SV) is selected for the ZR22S or the ZR202S.

- Connection: L9852CB Rc 1/4 or G7016XH 1/4 NPT
- Material: SUS316 (JIS)
- Weight: Approx. 80 g

**12. K9292DN/K9292DS Check Valve**

This is used to prevent entry of process gas into calibration gas line. Purpose is the same as stop valve, but is convenient, as it does not need to be opened or closed for calibration.

Mount directly on calibration gas inlet of detector in place of stop valve. However as source pressure of 150 kPa G or more is needed, standard gas unit cannot be used.

When option code "/CV" of the ZR22S or the ZR202S is specified, check valve is provided.

- Connection: K9292DN Rc1/4 or K9292DS 1/4 NPT
- Material: SUS304 (JIS)
- Pressure: Between 70 kPa G or more 350 kPa G or less
- Weight: Approx. 40g

**13. Air Set**

**G7003XF/K9473XK**

- Primary Pressure: Max. 1 MPa G
- Secondary Pressure: 0.02 to 0.2 MPa G
- Connection: Rc1/4 or 1/4 NPT with joint adapter

**G7004XF/K9473XG**

- Primary Pressure: Max. 1 MPa G
- Secondary Pressure: 0.02 to 0.5 MPa G
- Connection: Rc1/4 or 1/4 NPT with joint adapter

**14. G7013XF/G7014XF Cylinder Pressure Regulator**

- Primary Pressure: 14.8 MPa G,
- Secondary Pressure: 0 to 0.4 MPa G
- Connection: Inlet W22 14 threads, right hand screw  
Outlet Rc1/4 or 1/4NPT
- Material: Brass body

**15. ZR22A, ZR202A Heater Assembly**

- ZR22A: Spare Parts for ZR22S
- ZR202A: Spare Parts for ZR202S
- (Note) Yokogawa shall not guarantee the heater assembly after its replacement.

**16. E7044KF Case Assembly of Calibration Cylinder**

- Case Paint: Baked epoxy resin,  
Jade green (Munsell 7.5 BG 4/1.5)
- Installation: 2B pipe mounting
- Weight: Approx. 10kg
- (Note) Export of such high pressure filled gas cylinders to most countries is prohibited or restricted.

**STANDARD ACCESSARIES**

ZR402G

Item	Parts. No.	Q'ty	Description
Fuse	A1113EF	1	3.15A
Bracket	F9554AL	1	For pipe, panel, or wall mounting
Screws for Bracket	F9123GF	1	

T02.EPS

ZR22S

Item	Parts. No.	Q'ty	Description
Allen wrench	L9827AB	1	For lock screw

T02\_00.EPS

ZR202S

Item	Parts. No.	Q'ty	Description
Fuse	A1113EF	1	3.15A
Allen wrench	L9827AB	1	For lock screw

T02\_01.EPS

## Model and Suffix Codes

### 1. Separate type Explosionproof Zirconia Oxygen Analyzer, Detectors

Model	Suffix code	Option code	Description
ZR22S	-----	-----	Separate type Explosionproof Zirconia Oxygen Analyzer, Detector
Explosion proof Approval	-A	-----	ATEX certified flameproof (*11)
	-B	-----	FM certified explosionproof
	-C	-----	CSA certified explosionproof
	-D	-----	IECEX certified flameproof (*12)
Length	-015	-----	0.15 m (for high temperature use) (*1)
	-040	-----	0.4 m
	-070	-----	0.7 m
	-100	-----	1.0 m
	-150	-----	1.5 m
	-200	-----	2.0 m
Wetted material	-S	-----	SUS316
	-C	-----	Stainless steel with Inconel calibration gas tube (*7)
Flange (*2)	-A	-----	ANSI Class 150 2 RF SUS304 (*10)
	-B	-----	ANSI Class 150 3 RF SUS304
	-C	-----	ANSI Class 150 4 RF SUS304
	-E	-----	DIN PN10 DN50 A SUS304 (*10)
	-F	-----	DIN PN10 DN80 A SUS304
	-G	-----	DIN PN10 DN100 A SUS304
	-K	-----	JIS 5K 65 FF SUS304
	-L	-----	JIS 10K 65 FF SUS304
	-M	-----	JIS 10K 80 FF SUS304
	-P	-----	JIS 10K 100 FF SUS304
	-Q	-----	JIS 5K 32 FF SUS304 (for high temperature use) (*3)
	-R	-----	JPI Class 150 4 RF SUS304
	-S	-----	JPI Class 150 3 RF SUS304
-W	-----	Westinghouse	
Reference air	-E	-----	External connection (Instrument air) (*8)
Gas Thread	-R	-----	Rc 1/4
	-T	-----	1/4 NPT
Connection box thread	-M	-----	M20 x 1.5 mm
	-T	-----	1/2 NPT (*9)
Instruction manual	-E	-----	English
—	-A	-----	Always -A
Options	Valves	/C	Inconel bolt (*4)
		/CV	Check valve (*5)
	Tag plates	/SV	Stop valve (*5)
		/SCT	Stainless steel tag plate (*6)
		/PT	Printed tag plate (*6)

T2.1E.EPS

- \*1 Used with the ZO21P High Temperature Probe Adapter. Select flange (-Q).
- \*2 The thickness of the flange depends on its dimensions.
- \*3 The flange thickness does not conform to JIS specification.
- \*4 Inconel probe bolts and U shape pipe are used. Use this option for high temperature use (ranging from 600 to 700°C).
- \*5 Specify either /CV or /SV option code. Please select /CV or /SV.
- \*6 Specify either /SCT or /PT option code.
- \*7 Recommended if measured gas contains corrosive gas like chlorine.
- \*8 Piping for reference air must be installed to supply reference air constantly at a specified flow rate.
- \*9 When selecting code -B (FM certified explosionproof) or -C (CSA certified explosionproof), select code -T (1/2 NPT).
- \*10 Confirm inside diameter of pipe attached to customer's flange in case that -A or -E is selected.
- \*11 Certified cable glands that meet or exceed the requirements for EExd II B+H<sub>2</sub> IP66, provide at least 6 threads engaged when installed, and resist heat so that they can be used in the operating environment, should be used.
- \*12 Certified cable glands that meet or exceed the requirements for Exd II B+H<sub>2</sub> T2, Ex tD A21 IP66 T300°C, provide at least 6 threads engaged when installed, and resist heat so that they can be used in the operating environment, should be used.

**2. Separate type General Purpose Zirconia Oxygen Analyzer, Converter**

Model	Suffix code	Option code	Description
ZR402G	-----	-----	Separate type Zirconia Oxygen Analyzer, Converter
Converter thread	-P -G -M -T	----- ----- ----- -----	G1/2 Pg13.5 M20x1.5 mm 1/2NPT
Display	-J -E -G -F -C	----- ----- ----- ----- -----	Japanese English German French Chinese
Instruction manual	-J -E -C	----- ----- -----	Japanese English Chinese
—	-A	-----	Always -A
Options		/H	Hood (*2)
Tag plates		/SCT /PT	Stainless steel tag plate (*1) Printed tag plate (*1)
NAMUR NE43 compliant		/C2	Failure alarm down-scale: Output status at CPU failure and hardware error is 3.6 mA or less (*3)
		/C3	Failure alarm up-scale: Output status at CPU failure and hardware error is 21.0 mA or more (*3)

T03.EPS

\*1 Specify either /SCT or /PT option code.

\*2 Sun shield hood is still effective even if scratched.

\*3 Output signal limits: 3.8 to 20.5 mA. Specify either /C2 or /C3 option code.

3. Integrated type Explosionproof Zirconia Oxygen Analyzer

Model	Suffix code	Option code	Description
ZR202S	-----	-----	Integrated type Explosionproof Zirconia Oxygen Analyzer
Explosion proof Approval	-A -B -C -D	----- ----- ----- -----	ATEX certified flameproof (*11) FM certified explosionproof CSA certified explosionproof IECEX certified flameproof (*12)
Length	-040 -070 -100 -150 -200	----- ----- ----- ----- -----	0.4 m 0.7 m 1.0 m 1.5 m 2.0 m
Wetted material	-S -C	----- -----	SUS316 Stainless steel with Inconel calibration gas tube (*7)
Flange (*1)	-A -B -C -E -F -G -K -L -M -P -R -S -W	----- ----- ----- ----- ----- ----- ----- ----- ----- ----- ----- ----- -----	ANSI Class 150 2 RF SUS304 (*10) ANSI Class 150 3 RF SUS304 ANSI Class 150 4 RF SUS304 DIN PN10 DN50 A SUS304 (*10) DIN PN10 DN80 A SUS304 DIN PN10 DN100 A SUS304 JIS 5K 65 FF SUS304 JIS 10K 65 FF SUS304 JIS 10K 80 FF SUS304 JIS 10K 100 FF SUS304 JPI Class 150 4 RF SUS304 JPI Class 150 3 RF SUS304 Westinghouse
Auto Calibration	-N -A -B	----- ----- -----	Not required Horizontal mounting (*5) Vertical mounting (*5)
Reference air	-E	-----	External connection (Instrument air) (*8)
Gas Thread	-R -T	----- -----	Rc 1/4 1/4 NPT(F)
Connection box thread	-M -T	----- -----	M20x1.5 mm 1/2 NPT (*9)
Instruction manual	-E	-----	English
—	-A	-----	Always -A
Options	Valves  Tag plates  NAMUR NE43 compliant	/C /CV /SV /H /SCT /PT /C2   /C3	Inconel bolt (*2) Check valve (*3) Stop valve (*3) Hood (*6) Stainless steel tag plate (*4) Printed tag plate (*4) Failure alarm down-scale: Output status at CPU failure and hardware error is 3.6 mA or less (*13) Failure alarm up-scale: Output status at CPU failure and hardware error is 21.0 mA or more (*13)

\*1 The thickness of the flange depends on its dimensions.  
 \*2 Inconel probe bolts and U shape pipe are used. Use this option for high temperature use (ranging from 600 to 700°C).  
 \*3 Specify either /CV or /SV option code.  
 \*4 Specify either /SCT or /PT option code.  
 \*5 No need to specify the option codes, /CV and /SV, since the check valves are provided with the autocalibration unit.  
 \*6 Sun shield hood is still effective even if scratched. Hood is necessary for outdoor installation out of sun shield roof.  
 \*7 Recommended if measured gas contains corrosive gas like chlorine.  
 \*8 Piping for reference air must be installed to supply reference air constantly at a specified flow rate.  
 \*9 When selecting code -B (FM certified explosionproof) or -C (CSA certified explosionproof), select code -T(1/2 NPT).  
 \*10 Confirm inside diameter of pipe attached to customer's flange in case that -A or -E is selected.  
 \*11 Certified cable glands that meet or exceed the requirements for EExd II B+H2 IP66, provide at least 6 threads engaged when installed, and resist heat so that they can be used in the operating environment, should be used.  
 \*12 Certified cable glands that meet or exceed the requirements for Exd II B+H2 T2, Ex tD A21 IP66 T300°C, provide at least 6 threads engaged when installed, and resist heat so that they can be used in the operating environment, should be used.  
 \*13 Output signal limits: 3.8 to 20.5 mA. Specify either /C2 or /C3 option code.

T05.EPS

**4. Adapter for High Temperature Probe of separate type Oxygen Analyzer**

Model	Suffix code	Option code	Description
ZO21P	-H		High Temperature Probe Adapter
Material	-A -B		SiC SUS 310S
Insertion length	-100 -150		1.0 m 1.5 m
Flange	-J -N -M -L -A -R -Q -T -S -E		JIS 5K 50 FF SUS304 JIS 10K 65 FF SUS304t JIS 10K 80 FF SUS304 JIS 10K 100 FF SUS304 ANSI Class 150 4 RF SUS304 ANSI Class 150-2 1/2 RF SUS304 ANSI Class 150 3 RF SUS304 JPI Class 150 3 RF SUS304 JPI Class 150 4 RF SUS304 DIN PN10 DN50 A SUS304
Style code	*A		Style A

T06.EPS

Note: For this high-temperature use probe adapter, be sure to specify the ZR22S probe of its insertion length 0.15 meters.

**High temperature Probes (Spare Parts)**

Part No.	Description
E7046AL	SiC, insertion length 1.0 m
E7046BB	SiC, insertion length 1.5 m
E7046AP	SUS310S, insertion length 1.0 m
E7046AQ	SUS310S, insertion length 1.5 m

T07.EPS

**5. Auxiliary Ejector for High Temperature Use of separate type Oxygen Analyzer**

Part No.	Description
E7046EC	Rc 1/4 $\phi$ 6 / $\phi$ 4 TUBE joint: SUS304 (JIS)
E7046EN	1/4 NPT, 1/4 TUBE joint: SUS304 (JIS)

T08.EPS

**6. Probe Protector for Zirconia Oxygen Analyzers**

Model	Suffix code	Option code	Description
ZO21R	-L		Probe Protector(0 to 700°C)
Insertion length	-100		1.05 m (3.5 ft)
Flange (*1)	-J -A		JIS 5K 65 FF SUS304 ANSI Class 150 4 FF SUS304
Style code	*B		Style B

\*1 Thickness of flange depends on dimensions of flange.

T09.EPS

**7. Standard Gas Unit**

Model	Suffix code	Option code	Description
ZO21S			Standard gas unit
Power supply	-2		200 V AC 50/60 Hz
	-3		220 V AC 50/60 Hz
	-4		240 V AC 50/60 Hz
	-5		100 V AC 50/60 Hz
	-7		110 V AC 50/60 Hz
	-8		115 V AC 50/60 Hz
Panel	-J		Japanese version
	-E		English version
Style code	*A		Style A

T10.EPS

**8. Flow setting unit for manual calibration (Needs instrument air.)**

Model	Suffix code	Option code	Description
ZA8F			Flow setting unit
Joint	-J		Rc 1/4
	-A		With 1/4" NPT adapter
Style code	*B		Style B

T11.EPS

### 9. Automatic Calibration Unit for Separate type Analyzer (Needs instrument air.)

Model	Suffix code	Option code	Description
ZR40H	.....	.....	Automatic calibration unit for ZR402G
Gas piping connection	-R .....	.....	Rc 1/4
	-T .....	.....	1/4" NPT
Wiring connection	-P .....	.....	Pipe connection (G1/2)
	-G .....	.....	Pg 13.5
	-M .....	.....	20 mm (M20 x 1.5)
	-T .....	.....	1/2 NPT
—	-A		Always -A

(\*) CE marking (pending).

T12.EPS

### 10. Automatic Calibration Unit for Integrated type Analyzer ZR202S

When Auto Calibration of (-A) or (-B) code is specified, Auto Calibration Unit is installed in ZR202S.

When (-N) is selected, Auto Calibration Unit is not available.

### 11. Stop Valve for Calibration-gas line

Stop valve

Part No.	Description
L9852CB	Joint: Rc 1/4, Material: SUS316 (JIS)
G7016XH	Joint: 1/4 NPT, Material: SUS316 (JIS)

Nipple

Part No.	Description
G7209XA	R 1/4, Material: SUS316 (JIS)
K9470ZN	1/4 NPT, Material: SUS316 (JIS)

T14.EPS

### 12. Check Valve for Calibration-gas line

Part No.	Description
K9292DN	Joint: Rc 1/4, Material: SUS304 (JIS)
K9292DS	Joint: 1/4 NPT, Material: SUS304 (JIS)

T15.EPS

### 13. Air Set

Part No.	Description
G7003XF	Joint: Rc 1/4, Material: Zinc alloy
K9473XK	Joint: 1/4 NPT(F), Material: Zinc alloy with adapter
G7004XF	Joint: Rc 1/4, Material: Zinc alloy
K9473XG	Joint: 1/4 NPT(F), Material: Zinc alloy with adapter

T16.EPS

### 14. Pressure Regulator for Gas Cylinder

Part No.	Description
G7013XF	Inlet: W22 14 threads Outlet: Rc 1/4
G7014XF	Inlet: W22 14 threads Outlet: 1/4 NPT(F)

T18.EPS

### 15. Heater Assembly

Model	Suffix code	Option code	Description
ZR22A	.....	.....	Heater Assembly for ZR22
Length (*1)	-015 .....	.....	0.15 m
	-040 .....	.....	0.4 m
	-070 .....	.....	0.7 m
	-100 .....	.....	1 m
	-150 .....	.....	1.5 m
	-200 .....	.....	2 m
Jig for change	-A .....	.....	with Jig (*2)
	-N .....	.....	None
—	-A		Always -A

\*1 Suffix code of length should be selected as same as ZR22S installed.

\*2 Jig part no. is K9470BX to order as a parts after purchase.

(Note) The heater is made of ceramic, do not drop or subject it to pressure stress.

Yokogawa shall not guarantee the heater assembly after its replacement.

T20.EPS

Model	Suffix code	Option code	Description
ZR202A	.....	.....	Heater Assembly for ZR202
Length (*1)	-040 .....	.....	0.4 m
	-070 .....	.....	0.7 m
	-100 .....	.....	1 m
	-150 .....	.....	1.5 m
	-200 .....	.....	2 m
	Jig for change	-A .....	.....
-N .....		.....	None
—	-A		Always -A

\*1 Suffix code of length should be selected as same as ZR202S installed.

\*2 Jig part no. is K9470BX to order as a parts after purchase.

(Note) The heater is made of ceramic, do not drop or subject it to pressure stress.

Yokogawa shall not guarantee the heater assembly after its replacement.

T21.EPS

**EXTERNAL DIMENSIONS**

**1. ZR22S Separate type Explosionproof Zirconia Oxygen Analyzer, Detectors**

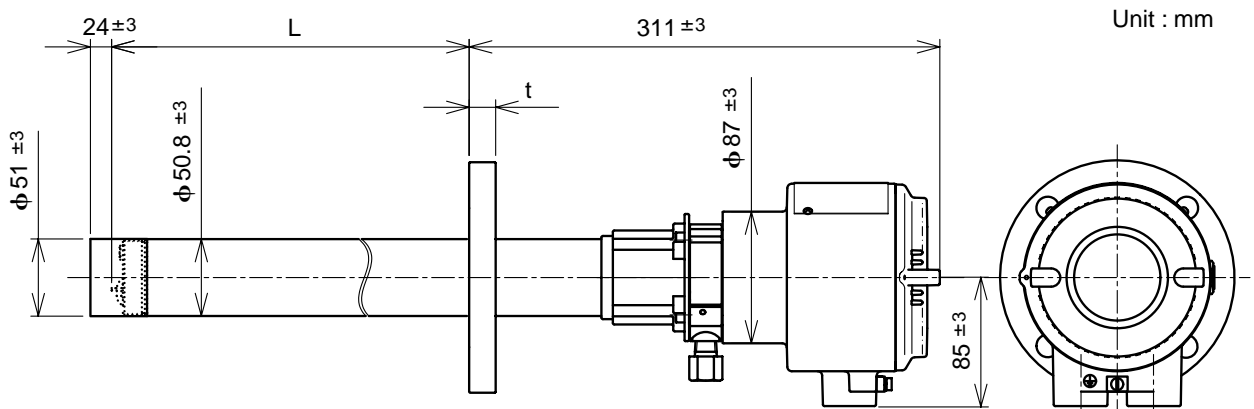

L (m)	tolerance (mm)
0.15	±4
0.4	±5
0.7	±7
1.0	±8
1.5	±10
2.0	±12

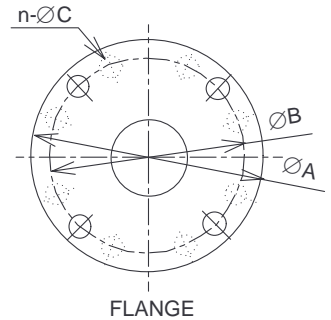
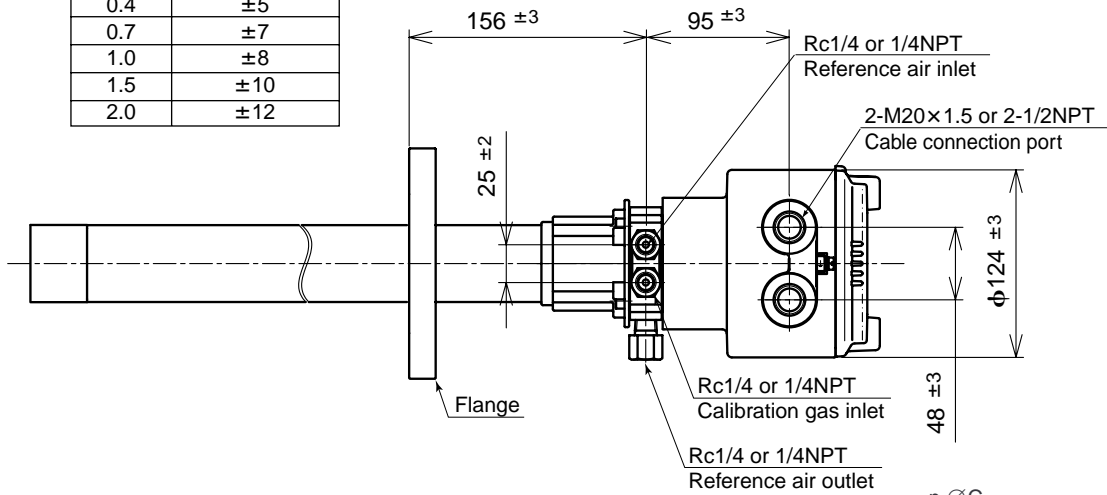

Flange	A	B	n	C	t
ANSI Class 150 2 RF SUS304	152.4	120.6	4	19	19
ANSI Class 150 3 RF SUS304	190.5	152.4	4	19	24
ANSI Class 150 4 RF SUS304	228.6	190.5	8	19	24
DIN PN10 DN50 A SUS304	165	125	4	18	18
DIN PN10 DN80 A SUS304	200	160	8	18	20
DIN PN10 DN100 A SUS304	220	180	8	18	20
JIS 5K 65 FF SUS304	155	130	4	15	14
JIS 10K 65 FF SUS304	175	140	4	19	18
JIS 10K 80 FF SUS304	185	150	8	19	18
JIS 10K 100 FF SUS304	210	175	8	19	18
JIS 5K 32 FF SUS304	115	90	4	15	5
JPI Class 150 4 RF SUS304	229	190.5	8	19	24
JPI Class 150 3 RF SUS304	190	152.4	4	19	24
Westinghouse	155	127	4	11.5	14

F2.1E.EPS

2. ZR402G Separate type Zirconia Oxygen Analyzers, Converter

Unit : mm

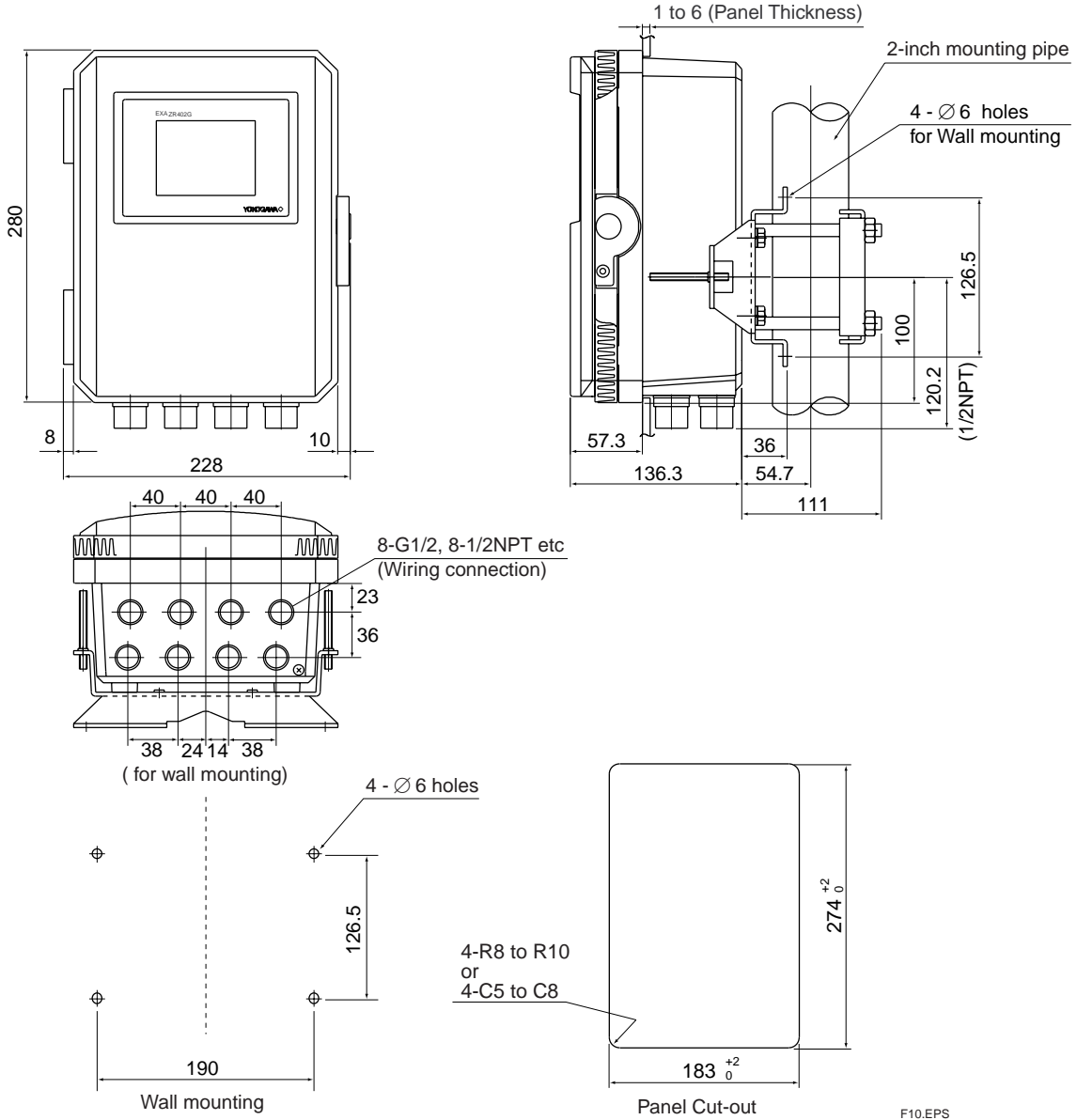

F10.EPS

● With sun shield hood (option code /H)

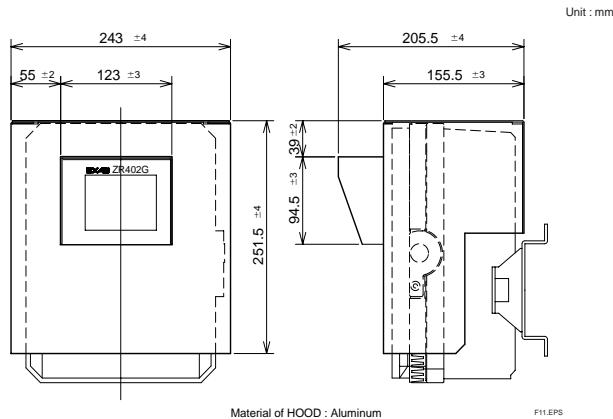

F11.EPS

3. ZR202S Integrated type Explosionproof Zirconia Oxygen Analyzers

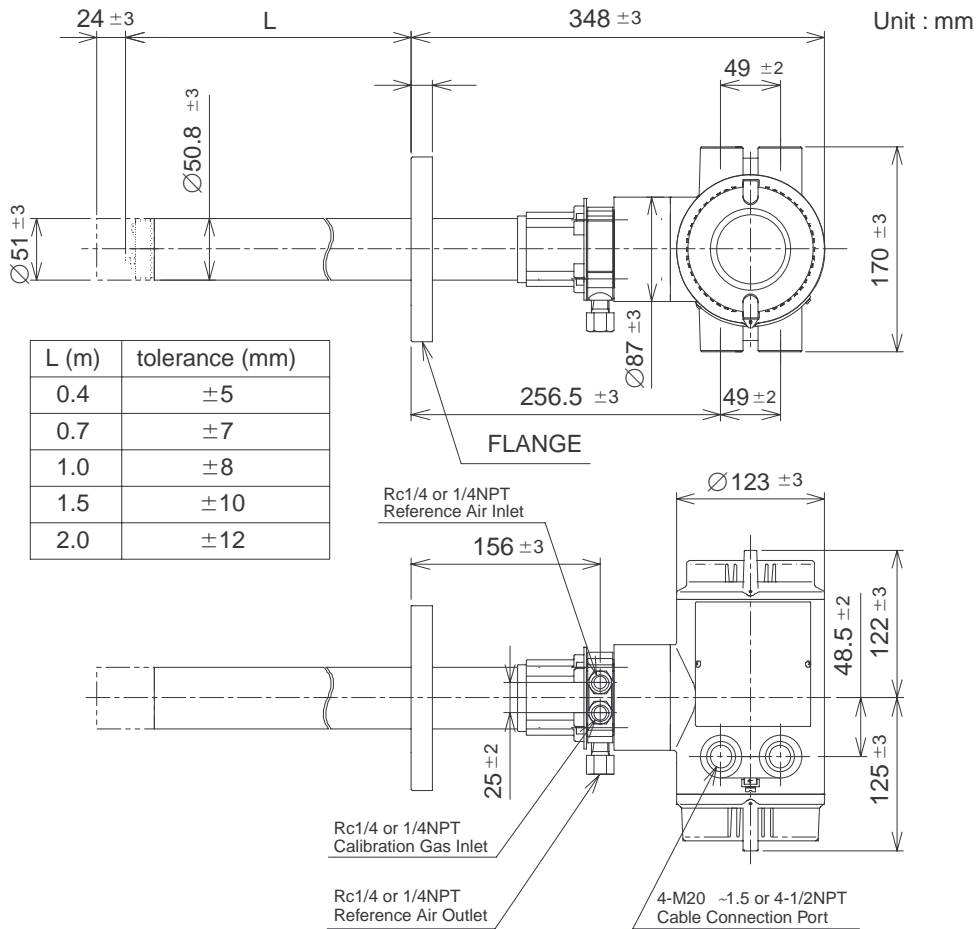

Flange	A	B	C	t
ANSI Class 150 2 RF SUS304	152.4	120.6	4 - Ø19	19
ANSI Class 150 3 RF SUS304	190.5	152.4	4 - Ø19	24
ANSI Class 150 4 RF SUS304	228.6	190.5	8 - Ø19	24
DIN PN10 DN50 SUS304	165	125	4 - Ø18	18
DIN PN10 DN80 SUS304	200	160	8 - Ø18	20
DIN PN10 DN100 SUS304	220	180	8 - Ø18	20
JIS 5K 65 FF SUS304	155	130	4 - Ø15	14
JIS 10K 65 FF SUS304	175	140	4 - Ø19	18
JIS 10K 80 FF SUS304	185	150	8 - Ø19	18
JIS 10K 100 FF SUS304	210	175	8 - Ø19	18
JPI Class 150 4 RF SUS304	229	190.5	8 - Ø19	24
JPI Class 150 3 RF SUS304	190	152.4	4 - Ø19	24
Westinghouse	155	127	4 - Ø11.5	14

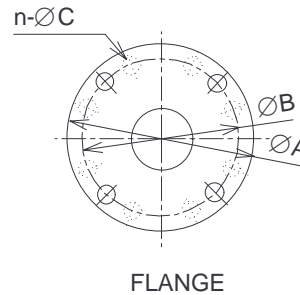

● With sun shield hood (option code /H)

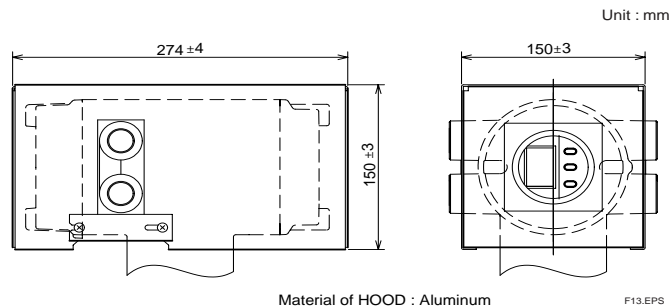

ZR202S Integrated type Explosionproof Zirconia Oxygen Analyzers

With Auto Calibration Unit (Horizontal Mount)

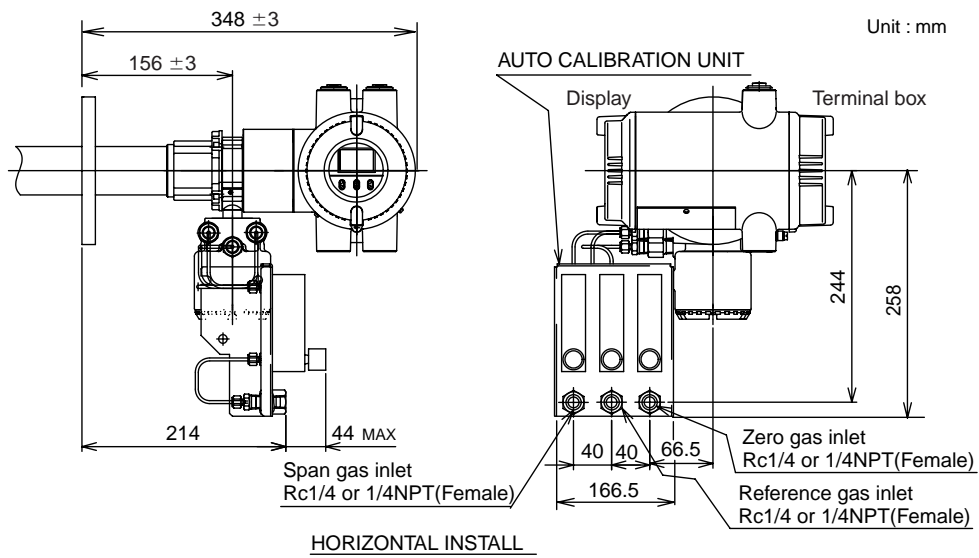

With Auto Calibration Unit (Vertical Mount)

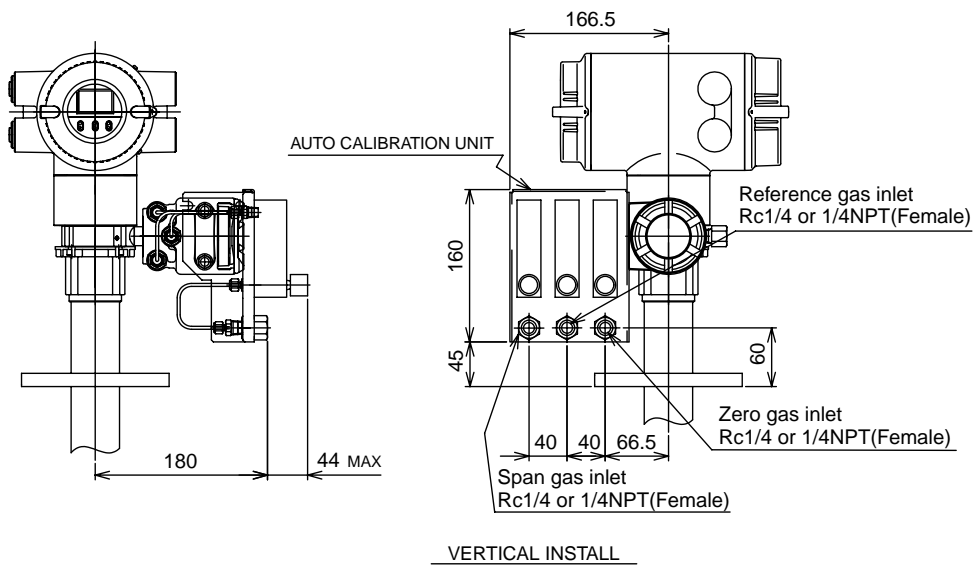

4. ZO21P Adapter for High Temperature Probe of separate type Explosionproof Oxygen Analyzer

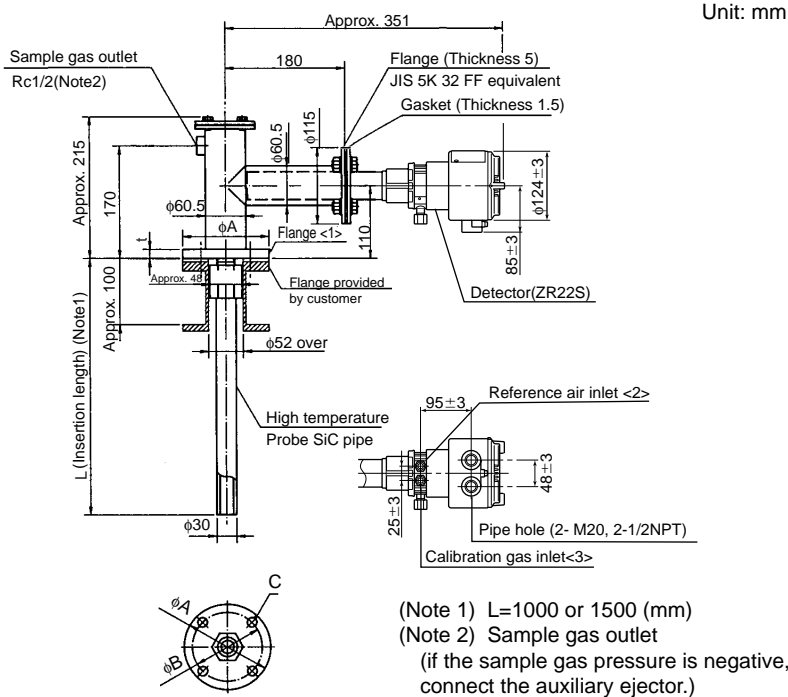

<1> Flange	<2>,<3> joint	A	B	C	t
JIS 5K 50 FF SUS304	Rc 1/4	130	105	4 - φ15	14
ANSI Class 150 4 RF SUS304	1/4 FNPT	228.6	190.5	8 - φ19	24

F14.EPS

5. E7046EC, E7046EN Auxiliary Ejector for High Temperature Use of separate type Oxygen Analyzer

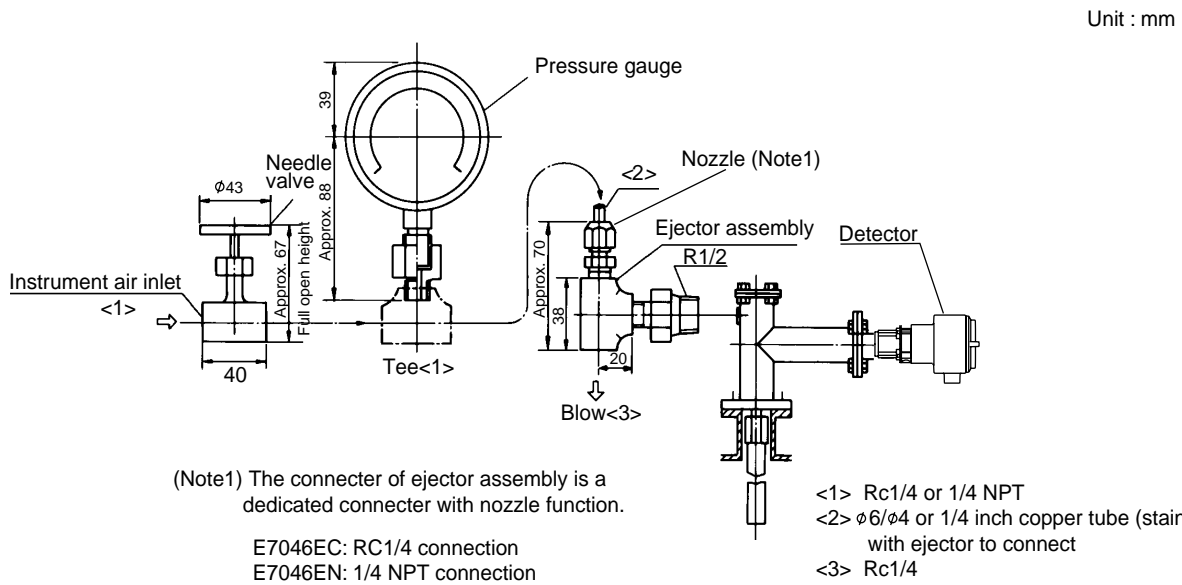

F15.EPS

6. ZO21R Probe Protector for Zirconia Oxygen Analyzers

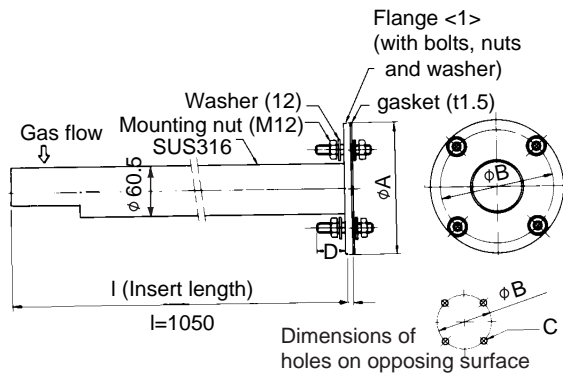

Flange<1>	A	B	C	t	D
JIS 5K 65 FF SUS304	155	130	4- $\phi 15$	5	40
ANSI Class 150 4 FF SUS304	228.6	190.5	8- $\phi 19$	12	50

F16.EPS

7. ZO21S Standard Gas Unit (Non CE Mark)

Unit : mm

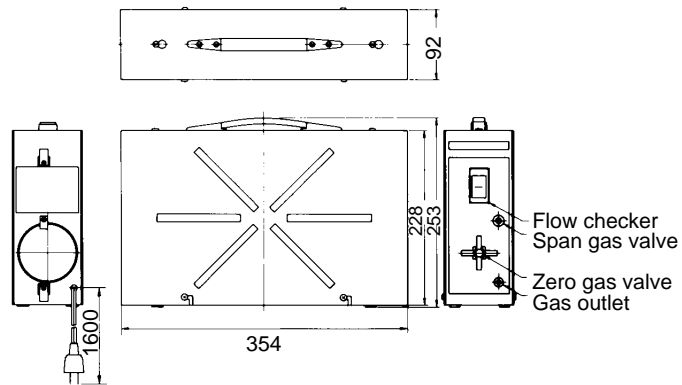

Zero gas cylinder (6 cylinder): E7050BA

F19.EPS

8. ZA8F Flow setting unit for manual calibration

Unit: mm

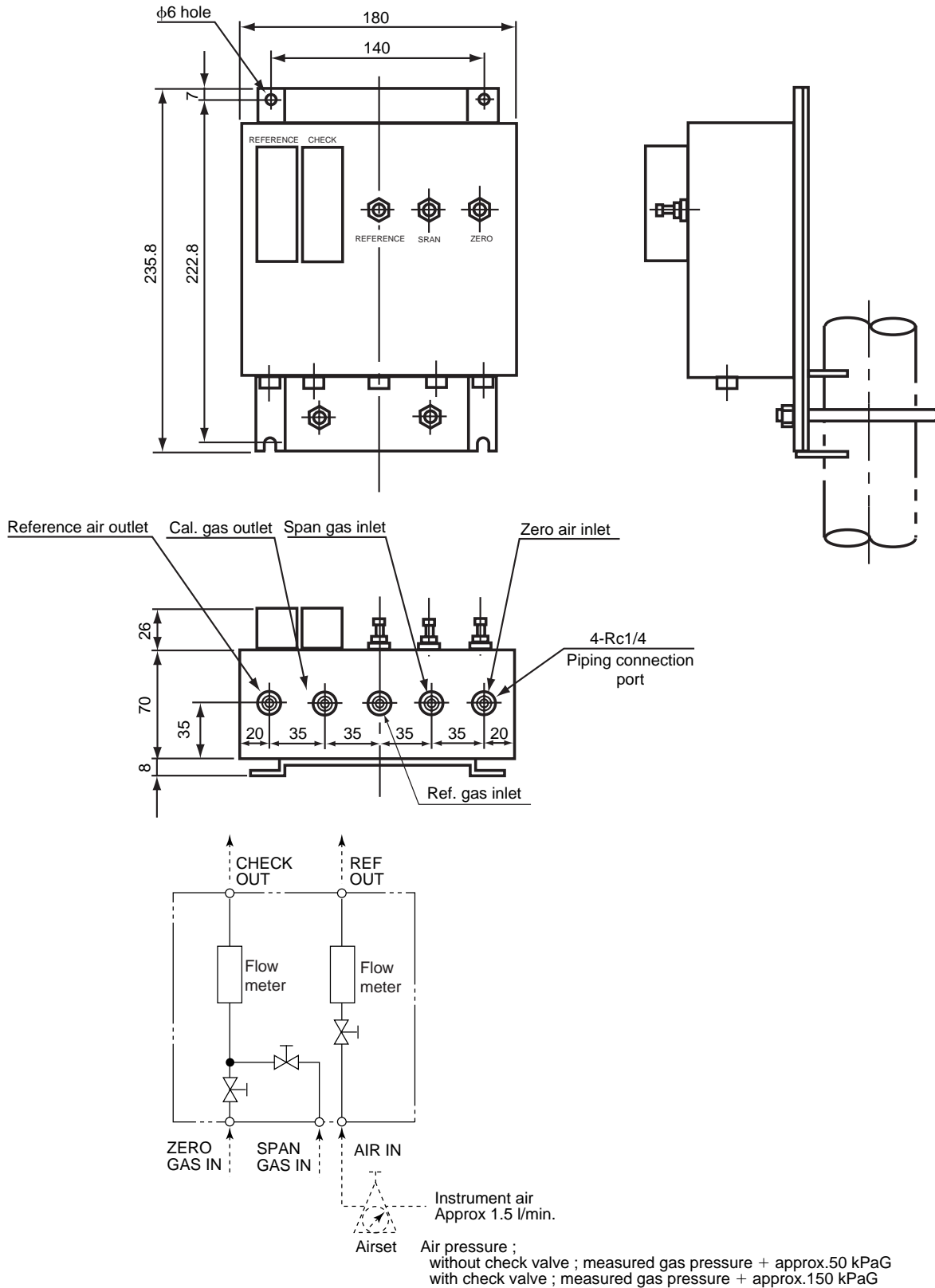

F20.EPS

9. ZR40H Automatic Calibration Unit for Separate type Analyzer

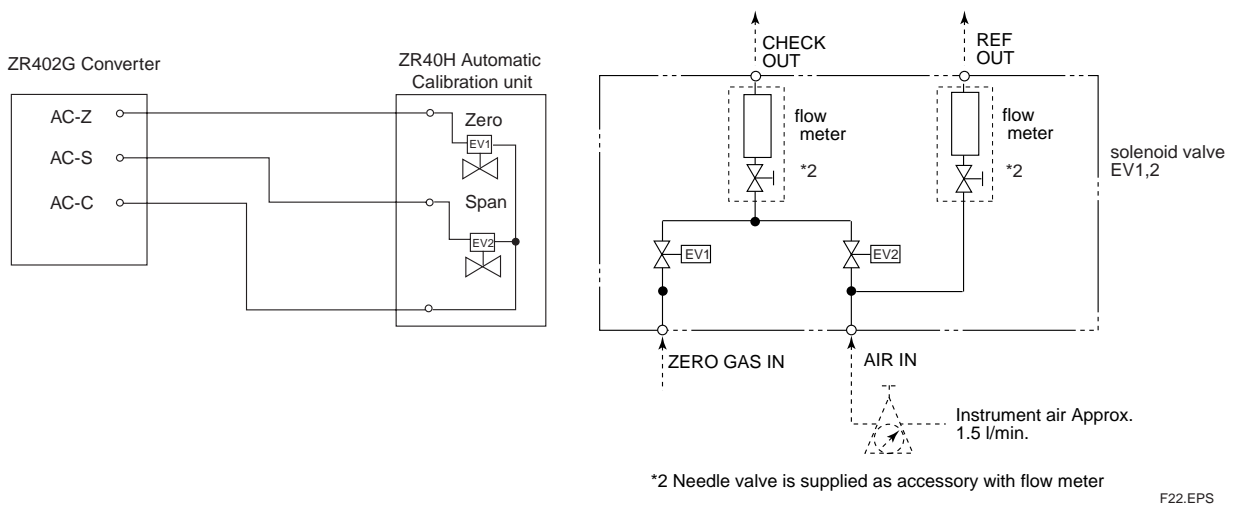
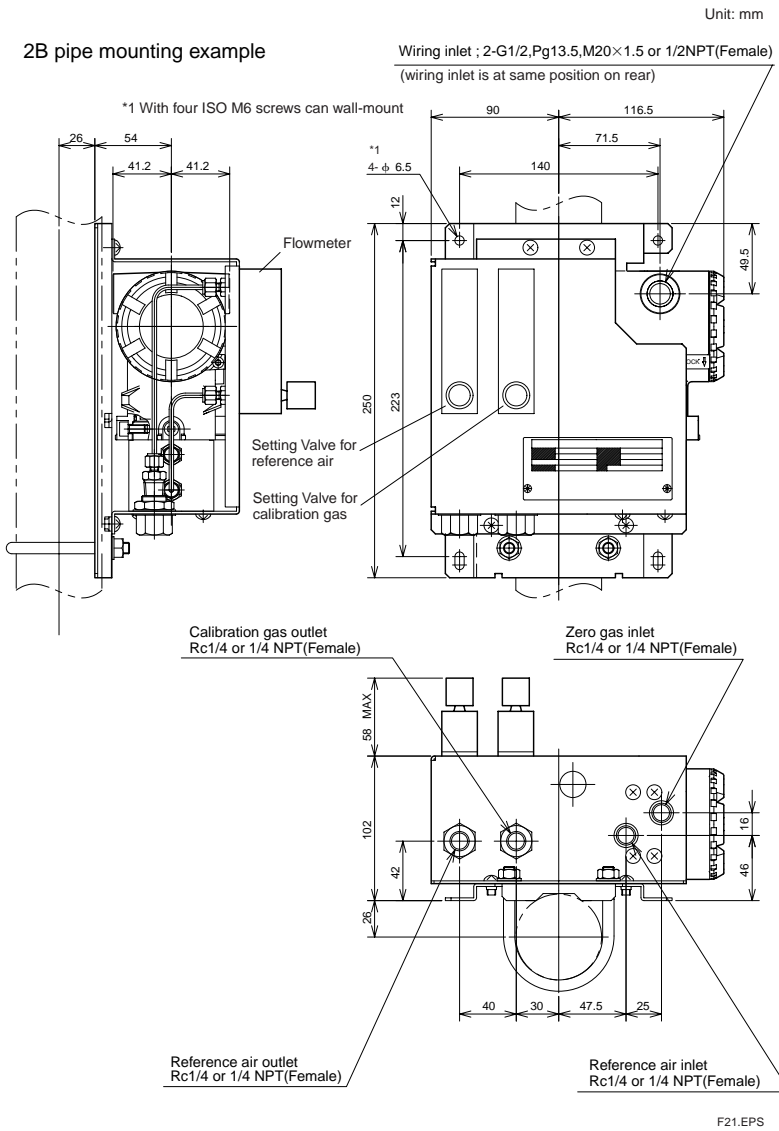

### 10. Automatic Calibration Unit for Integrated type Analyzer

When Auto Calibration of (-A) or (-B) code is specified, Auto Calibration Unit is installed in ZR202S.

Refer to the 20 Pages for the figure.

When (-N) is selected, Auto Calibration Unit is not available.

### 11. L9852CB /G7016XH Stop Valve for Calibration-gas line

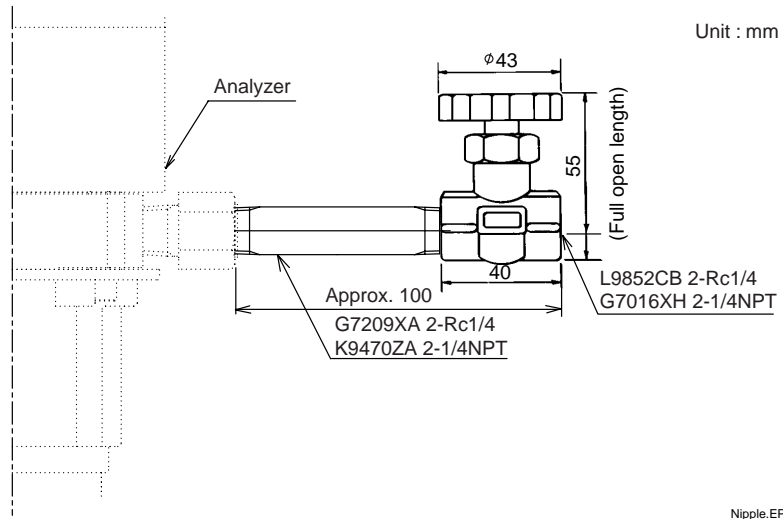

### 12. K9292DN /K9292DS Check Valve for Calibration-gas line

K9292DN : Rc 1/4(A),R 1/4(B)  
K9292DS : 1/4NPT(Female)(A),1/4NPT(Male)(B)

Unit: mm

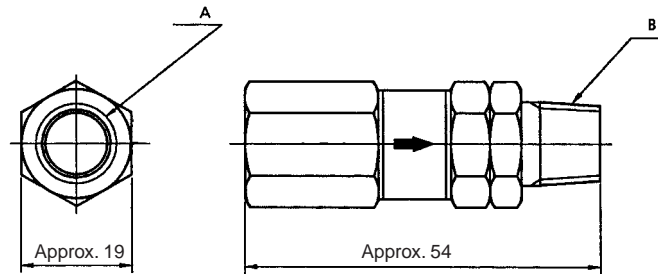

**13. Air Set G7003XF/K9473XK, G7004XF /K9473XG**

Unit : mm  
Dimensions in parentheses are approximate.

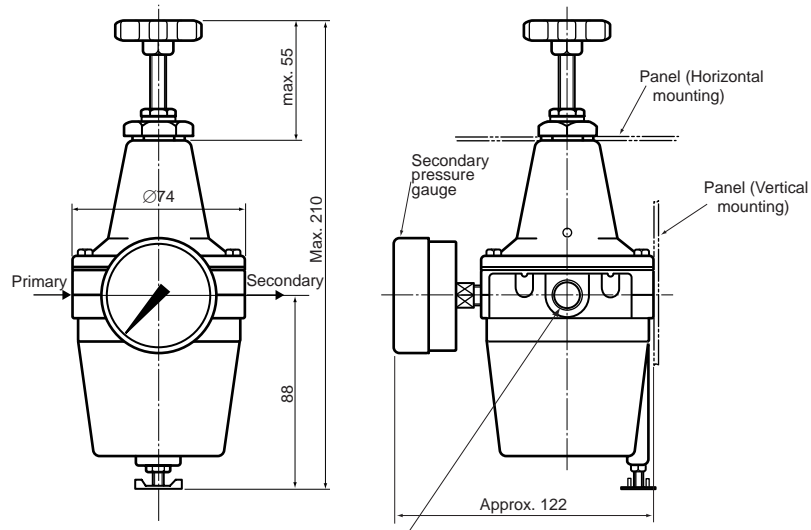

G7003XF, G7004XF: Rc 1/4  
K9473XK, K9473XG: 1/4NPT connector

F26-2.EPS

**14. G7013XF, G7014XF Pressure Regulator for Gas Cylinder**

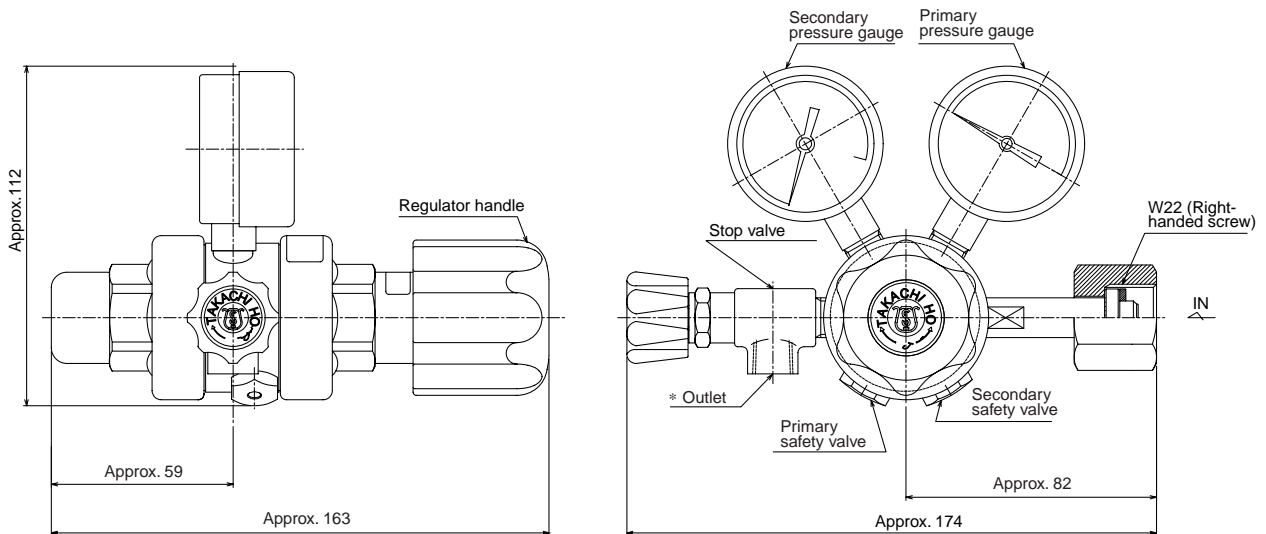

Part No.	* Outlet
G7013XF	Rc1/4
G7014XF	1/4 NPT female screw

**WIRING CONNECTIONS**

ZR402G Separate type Zirconia Oxygen Analyzer Converter

ZR22S Separate type Zirconia Oxygen Analyzer, Detector

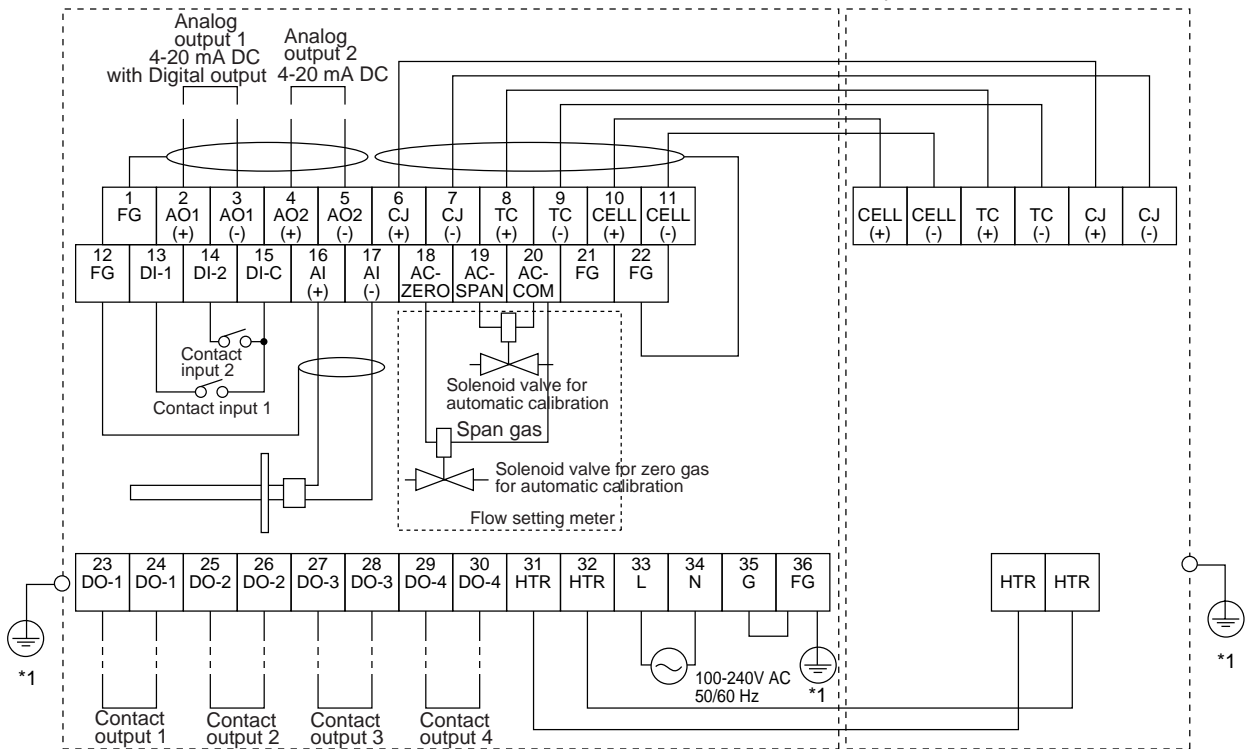

\*1 Grand resistance is 100 ohm or less.

F29.EPS

ZR202S Integrated type Zirconia Oxygen Analyzer

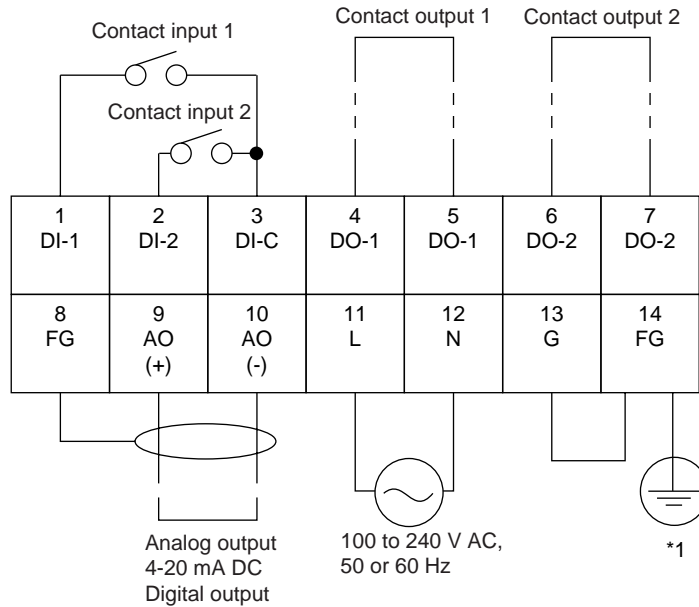

\*1 Ground resistance is 100 ohm or less.

F30.EPS

**Inquiry Sheet for Models ZR22S, ZR402G, and ZR202S Direct In Situ Zirconia Oxygen Analyzers**

Please place checkmarks in the appropriate boxes and fill in the necessary information in the blanks.

**1. General information**

Customer \_\_\_\_\_  
 Destination of delivery \_\_\_\_\_  
 Plant name \_\_\_\_\_  
 Measurement points \_\_\_\_\_

Separate type  Integrated type  
 Object :  indication  record  control  alarm  
 Fuel :  gas  oil  coal  \_\_\_\_\_  
 Power requirements \_\_\_\_\_V AC \_\_\_\_\_Hz

**2. Process conditions**

2.1 Measurement gas components \_\_\_\_\_  
 2.2 Oxygen concentration Nor. Min. Max.  vol% O<sub>2</sub>,   
 2.3 Temperature Nor. Min. Max.  °C,   
 2.4 Pressure Nor. Min. Max.  kPa,   
 2.5 Gas flow Nor. Min. Max.  m/sec,   
 2.6 Dust type, Size Nor. Min. μm quantity  g/Nm<sup>3</sup>,   
 2.7 Corrosive gas  No gas  Gas \_\_\_\_\_, quantity  ppm,   
 \_\_\_\_\_, quantity  ppm,   
 2.8 Combustible gas  No gas  Gas \_\_\_\_\_, quantity  ppm,   
 \_\_\_\_\_, quantity  ppm,   
 2.9 Others \_\_\_\_\_

**3. Installation site conditions**

3.1 Ambient temperature 1. Around Probe temp. from \_\_\_\_\_ to \_\_\_\_\_ °C, 2. Around Converter temp. from \_\_\_\_\_ to \_\_\_\_\_ °C  
 3.2 Vibration  No vibration  Vibration \_\_\_\_\_  
 3.3 1. Probe installation location  Furnace  Stack  Others \_\_\_\_\_  
 2. Probe position  Horizontal  Vertical  Others \_\_\_\_\_  
 Indoor  Outdoor  Covered  
 3. Probe insertion length (m) (Note)  0.15,  0.4,  0.7,  1.0,  1.5,  2.0  
 4. Flange  DIN \_\_\_\_\_  ANSI \_\_\_\_\_  Others \_\_\_\_\_  
 3.4 Converter location  Indoor  Outdoor  Covered (under roof)  
 3.5 Cable length between probe and converter \_\_\_\_\_ meters  
 3.6 Calibration method  Manual  Automatic

**4. Quotation data**

Quotation		Quantity	Description
Probe	ZR22S Explosionproof Probe		Refer to the Probe Configuration for probe selection.
	ZO21P-H High Temperature Use Probe Adapter		
	E7046EC /E7046EN Auxiliary Ejector for high temperature use.		
	Options (for general use) ZO21R Probe Protector for Oxygen Analyzer		
ZR402G Separate type Analyzer, Converter			
ZR202S Integrated type Explosionproof Zirconia Oxygen Analyzer			
ZO21S Standard Gas Unit			Select any one of Model ZO21S, ZA8F, ZR40H.
ZA8F Flow Setting Unit			
ZR40H Automatic Calibration Unit			
L9852CB /G7016XH Stop Valve			Not required if probe options are specified.
K9292DN /K9292DS Check Valve			
G7003XF/K9473XK, G7004XF/K9473XG Air Set			
G7013XF/G7014XF Pressure Regulator			
ZR22A, ZR202A Heater Assembly (Spare Parts)			

T22.EPS