

General Specifications

Model PH402G
Converter for pH and Redox (ORP)

EXA
CE

Flexibility, reliability and low maintenance are among the benefits offered by the EXA PH402 pH converter. Designed to meet the exacting requirements of measuring pH and ORP in the modern industrial environment, it contains many features to ensure the best precision whatever the application. This 4-wire unit is housed in a robust IP65 field mountable case. Two mA outputs, four relays, digital communication and a clear LCD make the PH402 a truly comprehensive package.

The PH402 features PI control on both the auxiliary mA outputs and the pulse proportional relay outputs, thus avoiding the need for a separate controller.

The famous EXA sensor diagnostics are enhanced in the PH402, including improved impedance testing, stability and response checks, and a personal computer logbook feature to record events like calibration data and diagnostic messages, show trends and help predict sensor failure.

The sensor washing cycle also provides an on-line response test, giving an immediate indication of sensor deterioration.

Microprocessor-aided calibration uses internal buffer tables and stability checking to ensure maximum accuracy with minimum effort. Process temperature compensation enhances accuracy in applications where the influence of temperature is seen in process changes. Also, pH & ORP or rH measurements can be made simultaneously with an appropriate sensor combination.



Features

- Universal pH/ORP, dual high impedance inputs
- On-line sensor checking
- RS485 communication interface
- Event logbook in software
- Process temperature compensation
- Wash cleaner with auto-start from diagnostics
- Four fully configurable SPDT contact outputs
- Two fully configurable mA outputs
- Built-in PI controller
- Easy to use EXA control panel

System configuration

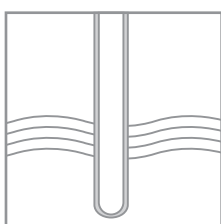

Sensors

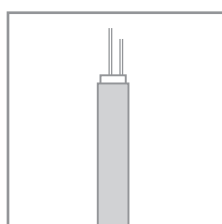

Cables

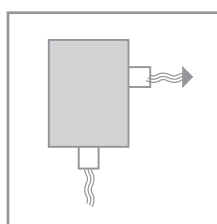

Fittings

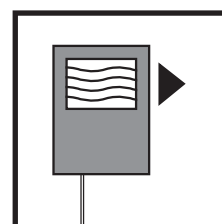

Transmitters

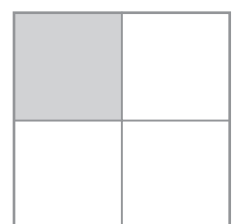

Accessories

Accurate pH Measurement

Electrode selection

In order to make precise pH measurements, there are a number of pre-requisites. Special attention should be paid to the choice of the sensors to ensure compatibility with the chemical composition of the process fluid. The speed of response required, the solids content and the flow rate of the fluid are also contributory factors. Other Yokogawa specification sheets cover the choice of sensors. Any Yokogawa sales office can provide expert advice.

Converter design

The system should be designed to minimize the effect of external influences. The EXA series features dual high impedance input amplifiers in a differential configuration with liquid earth. This system is used to ensure compatibility with most available sensor combinations. It also provides excellent noise rejection, minimizing the stray signals that can affect industrial pH measurements. Earth loop currents in damp and damaged cabling are eliminated by the equipotential screening. EXA instruments offer a simple and effective process temperature compensation in addition to the usual compensation to the Nernst equation.

Maintenance

It is important that the system be well maintained. The electrodes must be properly cleaned and regularly calibrated. Yokogawa on-line cleaning systems may be used where there is significant fouling of the sensors. Other influences from the electrode holders can be less obvious, but important none the less. Well designed fittings make it easy to provide the routine maintenance needed for best accuracy. Flow through, retractable and immersion assemblies are available.

The selection of the buffer solutions is important to ensure the best possible calibration. Yokogawa strongly recommends the use of NIST (NBS) buffers. These are chosen as primary buffer standards because of the maximum buffer capacity exhibited by these solutions. Commercial buffers (adjusted with NaOH) have the limited advantage of an integer value, with the disadvantages of loss of buffer capacity and greater temperature dependence. Yokogawa sets the pH / temperature relationships for NIST buffers in the software of the EXA pH converters. This combination provides the best calibration possible.

Accessories

Buffer powder packs to NIST (NBS) standard. Each box contains five (5) packets, each sufficient to make 200 ml of calibration solution when dissolved in distilled water.

Part No	pH value	Reference temperature
6C232	4.01	25°C
6C236	9.18	25°C
6C237	6.87	25°C

Input Circuitry

The input circuitry of the PH402 is a dual-amplifier system with liquid earth. Measuring electrode and reference electrode inputs are amplified separately against the liquid earth contact. Following a differential amplifier, normal signal processing takes place. This configuration provides the best immunity to noise, stray solution potentials and earth loops.

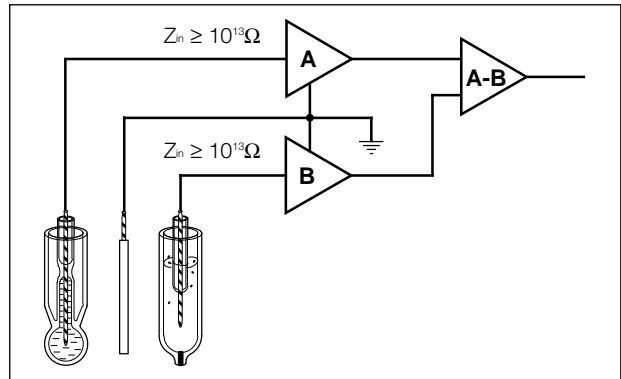

Dual amplifier system

The input amplifiers both have a very high input impedance ($>=10^{13}$ ohms). This means the PH402 is capable of accepting glass, enamel and metal measuring and reference sensors. Together with the ability to configure the ITP (isothermal point), the system can be adapted to accept almost all sensor types.

Process Temperature Compensation

The figure below shows the strong change in pH with temperature, caused by the dissociation constant of water changing. This effectively shifts the neutral point from pH 7. In order to reliably control the pH of solutions it is necessary to compensate for the changes. The EXA transmitters have a simple-to-operate system of process temperature compensation to provide optimum accuracy and best control. An application where this is particularly important is in the measurement of alkalinized boiler feed water.

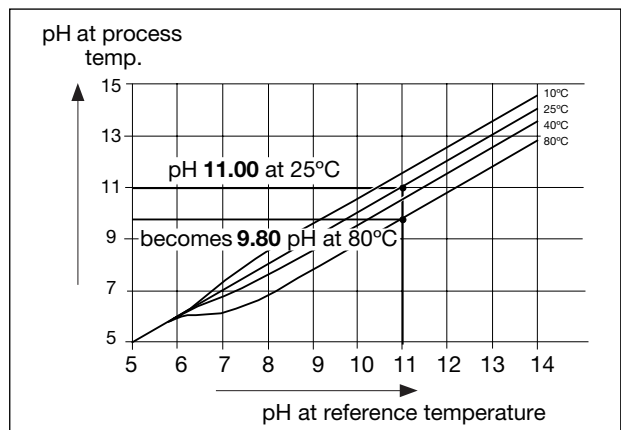

pH as a function of temperature

Three level operation

The EXA PH402 converter uses a 3-level operating system to take full advantage of the microprocessor while retaining the traditional simplicity of analog converters. Advanced functions are separated from conventional operation to avoid confusion. They can be activated as required for each individual application.

1. The normal maintenance functions are accessible through the flexible window by pushing the keys underneath.
2. Functions required to commission the instrument are hidden to discourage unauthorized tampering. The front cover is removed to reveal the commissioning menu and the hidden access key (marked *).
3. Specialized functions can be adjusted via the SERVICE menu. In this case access is by using "service codes."

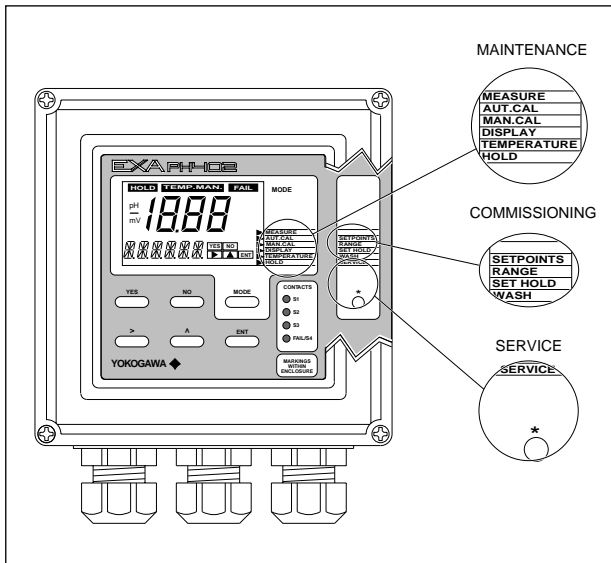

Three level operation

MAINTENANCE level

- Use : Normal operation and checking
- How : Simple operation by dialog through the closed front cover
- Example : Calibration with buffers

COMMISSIONING level

- Use : For normal commissioning
- How : Removal of the front cover reveals the access key and second menu
- Example : Output range setting

SERVICE level

- Use : Only for specialized functions
- How : Through special service code entries
- Example : Selecting process compensation

With this 3-level user-friendly approach, the instrument can be operated by anyone. Commissioning is straight-forward and needs no calibration equipment compared to analog instruments. Special functions available via access codes are invisible during normal operation. All three levels can be separately protected against unauthorized access by a password system using a three digit code.

Cables and Terminals

The PH402 is equipped with terminals suitable for the connection of finished cables in the size range of 0.13 to 4 mm² (26 to 12 AWG).

The glands will form a tight seal on cables of outside diameter in the range 7 to 12 mm (⁹/₃₂" to ¹⁵/₃₂").

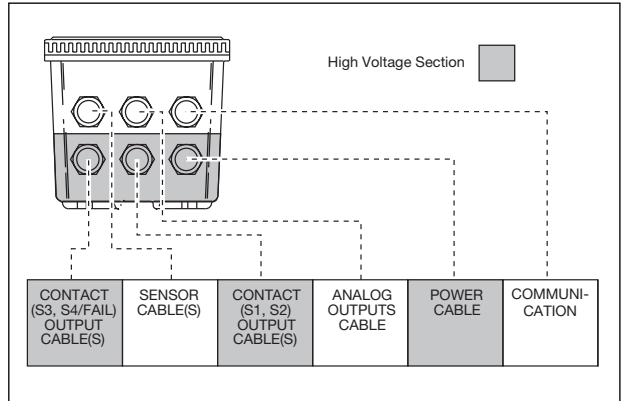

Glands to be used for cabling

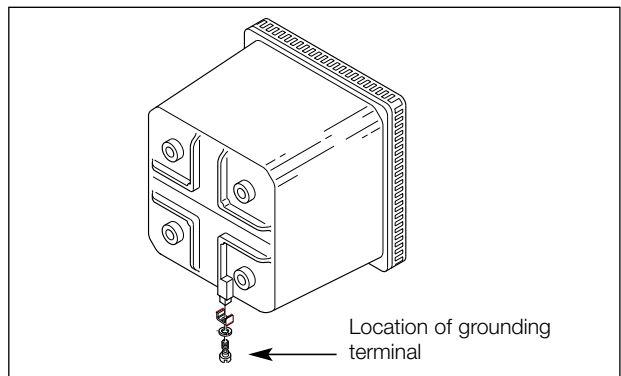

Grounding

Signal Processing (pH/ORP/rH)

With the correct sensor configuration it is possible to measure pH and ORP or rH (ORP is the oxidation reduction potential including the pH-component, rH compensates for the effect of pH). Combinations of two parameters can be displayed and transmitted separately on mA2.

Communications and Logbook

The EXA PH402 is equipped with RS485 communication ability. Communication lines are isolated from the input and output signals. Communication speed is selectable from 1200, 2400, 4800, 9600 baud. The format is selectable for even, odd, and no parity. The PH402 can be accessed over this 2-way communication link.

In combination with 2-way communication, there is a logbook feature. This is a software record of events, calibrations, alarms and the like. A total of approximately 100 events can be stored. New additions are made by overwriting the oldest entry, once 100 entries have been exceeded. Access is via the RS485 link, and Yokogawa's, PC402 software package. Important diagnostic information can also be read on the LCD display.

General Specifications

A. Input specifications : Dual high impedance inputs (2 x 10¹³Ω) with provision for liquid earth connection. Suitable for inputs from glass or enamel pH & reference sensors and ORP metal electrodes.

B. Input ranges
 - pH : -2 to 16 pH
 - ORP : -1500 to 1500 mV
 - rH : 0 to 55 rH
 - Temperature : -30 to 140 °C (-20 to 300 °F)
 for 8k55 sensor -10 to 120 °C (10 to 250 °F)
 for 10k NTC sensor -20 to 140 °C (0 to 300 °F)

C. Span
 - pH : min 1 max 20 pH
 - ORP : min 100 max 2000 mV
 - rH : min 2 max 55 rH
 - Temperature : min 25 °C max 200 °C
 min 50 °F max 400 °F
 for 8k55 sensor max 100 °C (250 °F)

D. Transmission signals
 : Two isolated outputs of 0/4-20 mA DC with common negative. Maximum load 600 Ω. Auxiliary output can be chosen from - pH, temperature, ORP or rH (with suitable sensor), P.I. control Burn up (22 mA) or Burn down (0/3.5 mA) to signal failure.

E. Temperature compensation
 - Range : Automatic or manual compensation to Nernst equation. Process compensation by configurable temperature coefficient. Adjustable ITP (Isothermal point of intersection).

F. Calibration
 : Semi-automatic using preconfigured NIST buffer tables 4, 7 & 9, or with user, defined buffer tables, with automatic stability check. Manual adjustment to grab sample. Slope and Asymmetry Potential setting. Zero point can be selected for calibration and display instead of As. Pot. (IEC746-2)

G. Serial communication
 : Bi-directional according to the EIA-485 standard using HART® protocol and PC402 software.

H. Logbook
 : Software record of important events and diagnostic data. Available through RS485, with key diagnostic information available in the display.

I. Display : Custom liquid crystal display, with a main display of 3½ digits 12.5 mm high. Message display of 6 alphanumeric characters, 7 mm high. Warning flags and units (pH and mV) as appropriate.

J. Contact outputs
 - General : Four (4) SPDT relay contacts with LED indicators. For S1, S2, and S3, the LED is on when relay is powered. NOTE: For S4 (FAIL) LED lights when power is removed (Fail safe). Contact outputs configurable for hysteresis and delay time.
 - Switch capacity : Maximum values 100 VA, 250 VAC, 5 Amps. Maximum values 50 Watts, 250 VDC, 5 Amps.
 - Status : High/Low process alarms, selected from pH, ORP, rH and temperature. Contact output is also available to signal "Hold Active"
 - Control function : On / Off
 PI pulsed - Proportional duty cycle control with integral term.
 PI frequency - Proportional frequency control with integral term.
 In addition wash cleaning control signal on S3, and FAIL alarm for system and diagnostic errors on S4

K. Contact input : Remote wash cycle start.

L. Power supply : 230 VAC ±15%, 50/60 Hz. Maximum consumption 10 VA. 115 VAC ±15%, 50/60 Hz. Maximum consumption 10 VA. 100 VAC ± 15% 50/60 Hz. Maximum consumption 10 VA. 24 VDC -20% / +30% Maximum consumption 10 Watts.

M. Input isolation : 1000 VDC

N. Shipping details : Package size w x h x d
 290 x 225 x 170 mm.
 11.5 x 8.9 x 6.7 in.
 Packed weight approx. 2.5 kg (5lb).

Modeland Suffix Codes

Model	Suffix	Option	Description
PH402G			pH/ORP transmitter
	-E		Always E
Supply voltage	-1		115 Volts 50/60 Hz
	-2		230 Volts 50/60 Hz
	-4		24 Volts DC
	-5		100 Volts 50/60 Hz
Instruction manual	-E		English language *
Options		/U	Pipe and wall mounting hardware
		/PM	Panel mounting hardware
		/Q	Quality certificate
		/SCT	Stainless steel tag

* For other languages contact local sales office

Operating Specifications

- A. Performance** : **pH**
- Linearity : $\leq 0.01 \text{ pH} \pm 0.02 \text{ mA}$
 - Repeatability : $\leq 0.01 \text{ pH} \pm 0.02 \text{ mA}$
 - Accuracy : $\leq 0.01 \text{ pH} \pm 0.02 \text{ mA}$
- Performance** : **ORP**
- Linearity : $\leq 1 \text{ mV} \pm 0.02 \text{ mA}$
 - Repeatability : $\leq 1 \text{ mV} \pm 0.02 \text{ mA}$
 - Accuracy : $\leq 1 \text{ mV} \pm 0.02 \text{ mA}$
- Performance** : **Temperature with Pt1000 Ω , 3 k Ω Balco, 5 k Ω and 10k NTC**
- Linearity : $\leq 0.2 \text{ }^\circ\text{C} \pm 0.02 \text{ mA}$
 - Repeatability : $\leq 0.1 \text{ }^\circ\text{C} \pm 0.02 \text{ mA}$
 - Accuracy : $\leq 0.3 \text{ }^\circ\text{C} \pm 0.02 \text{ mA}$
- Performance** : **Temperature with Pt100 Ω & 8k55 Ω**
- Linearity : $\leq 0.3 \text{ }^\circ\text{C} \pm 0.02 \text{ mA}$
 - Repeatability : $\leq 0.1 \text{ }^\circ\text{C} \pm 0.02 \text{ mA}$
 - Accuracy : $\leq 0.4 \text{ }^\circ\text{C} \pm 0.02 \text{ mA}$
- B. Ambient operating temperature**
- : -30 to +70 $^\circ\text{C}$ (-20 to 160 $^\circ\text{F}$)
for mA output
 - 10 to +70 $^\circ\text{C}$ (10 to 160 $^\circ\text{F}$) for LCD
- C. Storage temperature**
- : -30 to +70 $^\circ\text{C}$ (-20 to 160 $^\circ\text{F}$)
- D. Humidity**
- : 10 to 90% rH non-condensing
- E. Housing**
- : Cast aluminum case with chemically resistant coating, cover with flexible polycarbonate window. Case color is off-white and cover is moss green. Cable entry is via six 1/2" polyamide glands. Cable terminals are provided for up to 2.5 mm² finished wires. Weather resistant to IP65 and NEMA 4X standards. Pipe, wall or panel mounting, using optional hardware.
- F. Data protection**
- : EEPROM for configuration and log-book, and lithium battery for clock.
- G. Watchdog timer**
- : Checks microprocessor
- H. Automatic safeguard**
- : Return to measuring mode when no keystroke is made for 10 min.
- I. Power interruption**
- : Less than 50 milliseconds no effect. More than 50 milliseconds reset to measurement.
- J. Operation protection**
- : 3-digit programmable password.
- K. Regulatory compliance**
- EMC : meets council directive 89/336/EEC
 - Emission : meets EN 55022 Class A
 - Immunity : meets EN 50082-2
 - Low voltage : meets council directive 73/23/EEC
 - Installation : Designed for installation conforming to IEC 1010-1. Category II.

Sensor Checking

On-line checks

Real-time sensor checking is one of the important features of the EXA PH402. By special circuitry on the input board an alternating voltage is applied to the liquid earth pin and the sensors. The impedance of the measuring electrode (pH-glass or ORP-metal electrode) and reference electrode are independently measured. The measured values can be read in the second line of the display, and out-of-limit values trigger an alarm contact. Immediately after washing, the response time of the electrodes can be checked. (See page 6.)

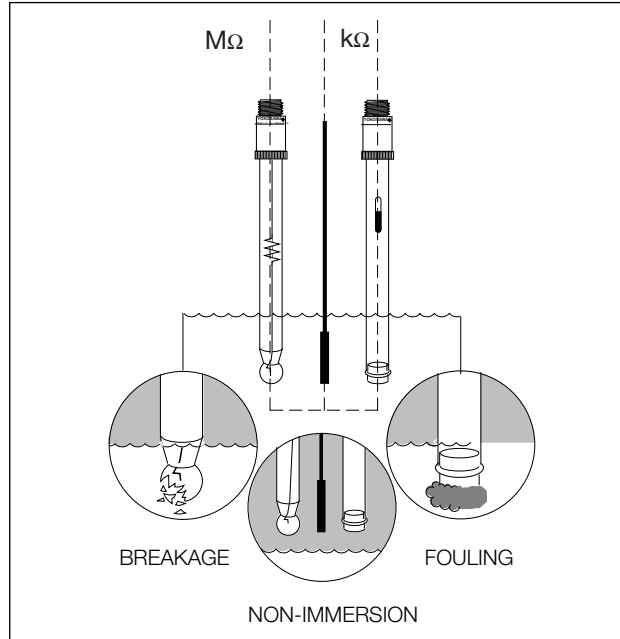

Sensor checking

Faults

All sensors are checked for high and low impedance, giving warning of breakage, non-immersion and cable problems. For reference sensors, fouling and electrolyte depletion is also detected.

These faults are signaled by the FAIL contact output and can be signaled to the control room by a current output of 22 mA, or 0/3.5 mA. The fault is also signaled by a special marker field on the display, a LED on the front and an error code in the message display.

Off-line checks

During calibration of a pH measuring system, the response of the sensors is measured and checked. Sensitivity and drift are calculated and checked.

During calibration of an ORP measuring system the drift of the sensors is calculated and checked. If any are outside the limits, an error is signaled.

The combination of on-line and off-line checking monitors all key aspects of the measurement to give an early warning if the reading is faulty.

Control and Alarm Functions

Control output (mA) : PI control on the 2nd mA output. The 2nd mA output can be configured to give a PI (proportional & integral) control output. The setpoint, proportional band and integral time are each fully programmable.

- Adjustable parameters : Setpoint, proportional range and integral time.

Process alarm : The contact will be switched when the process value reaches a limit. This can either be a high or low limit.

- Adjustable parameters : Setpoint for the process value
Hysteresis of the switching action
Delay time of the relay (0 to 200 s)

PI duty cycle control : The contact is used to control the time a solenoid dosing valve is opened. The proportional control is achieved by opening and closing the solenoid valve and varying the ratio of on and off time (t_{on} , t_{off}).

- Adjustable parameters : Setpoint, proportional range and integral time. Total time of the pulse period (5 to 100 s)

PI pulse frequency control : The contact is used to control a pulse-driven dosing pump. The frequency of pulses regulates the pump speed.

- Adjustable parameters : Setpoint, proportional range & integral time.
Pulse frequency (50 - 120 /min.)

Chemical cleaning of sensors : Contact S3 is used to control the wash cycle.

- Adjustable parameters : Cleaning time or washing time (t_w)
Recovery time after washing (t_r)
Interval time for wash cycle
An on-line dynamic response test of the electrode can be activated after cleaning.
In the example shown, within the "half-time" the pH should recover to more than 4.5. Otherwise an error message E11 will occur.

Fault alarm : Contact S4 by default set to function as an alarm, indicating that the EXA has found a fault in the measuring loop. If the self diagnostics of the EXA indicate a fault or error, the FAIL contact will be switched. In most cases this will be caused by a malfunction of the measuring loop.

The FAIL contact is also closed when the power is removed.

The "FAIL" contact may also be configured as a fourth process alarm.

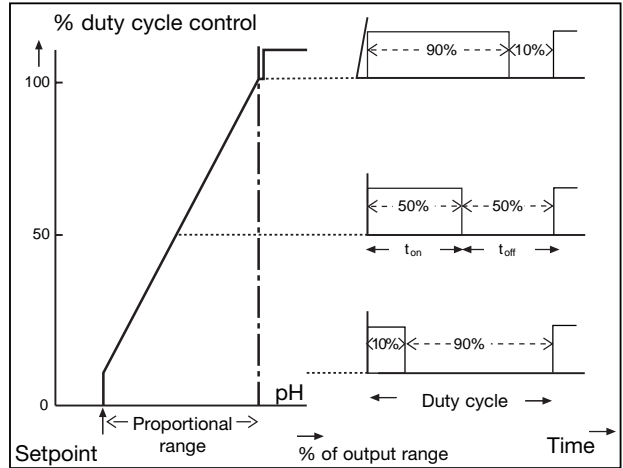

Duty cycle control

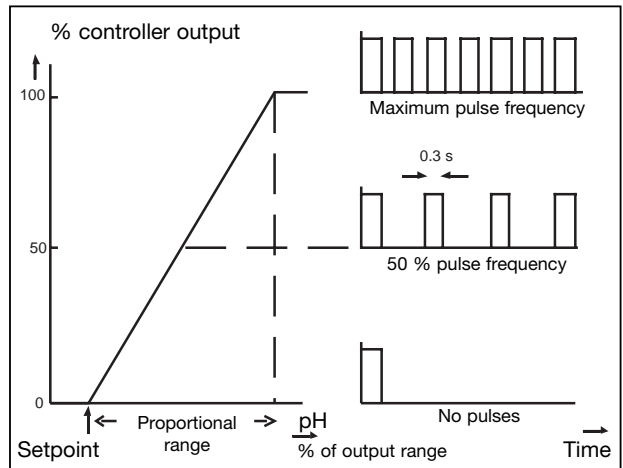

Pulse frequency control

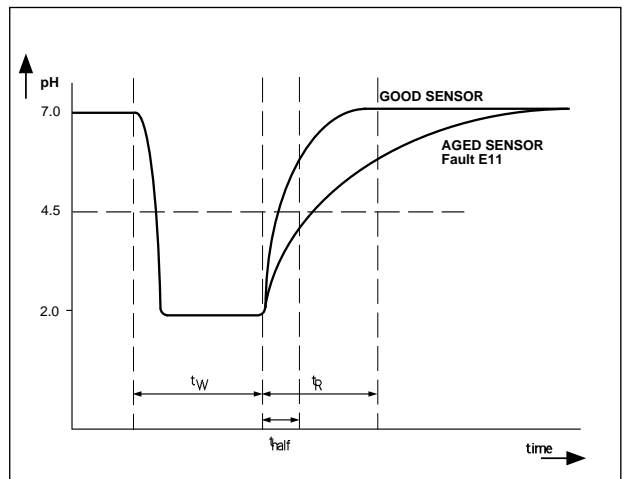

Dynamic response check after wash

System Configuration

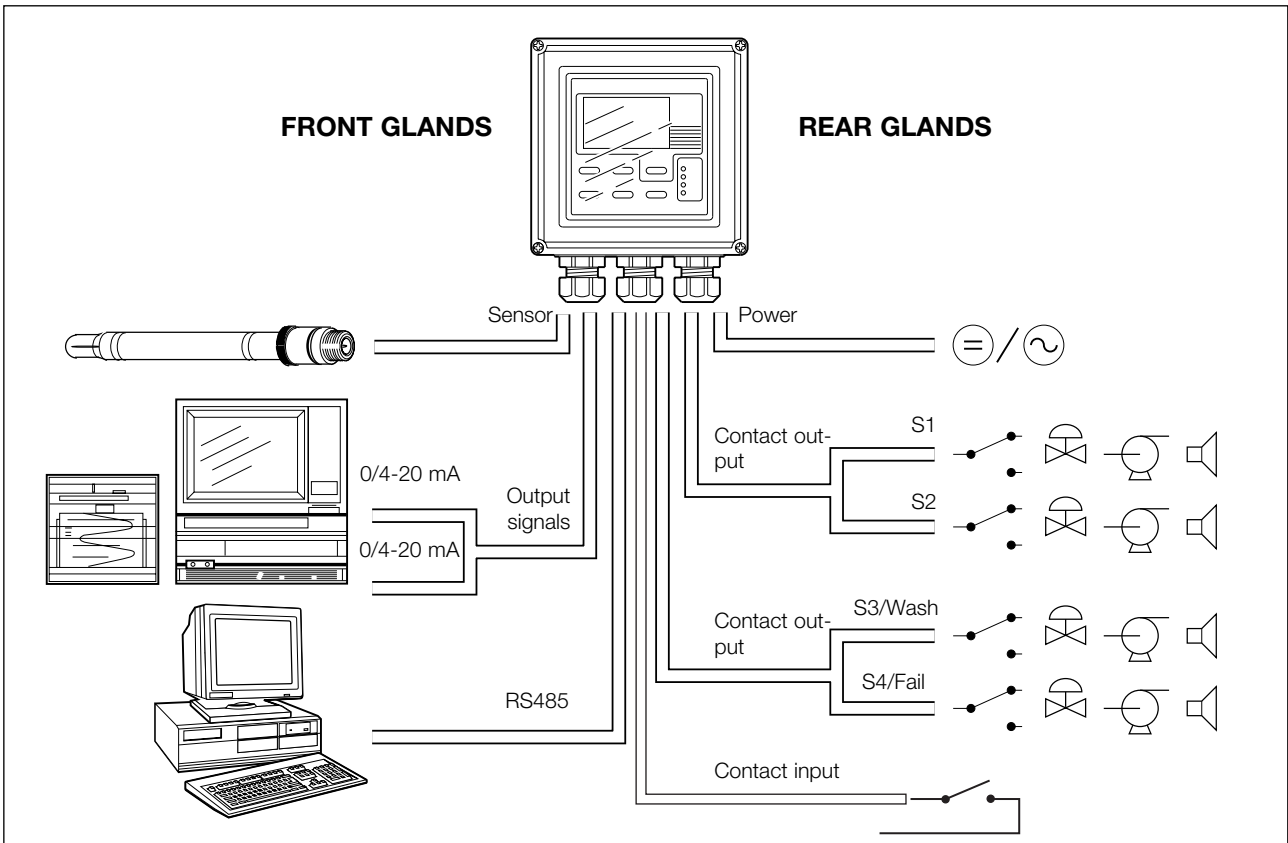

Input and Output Connections

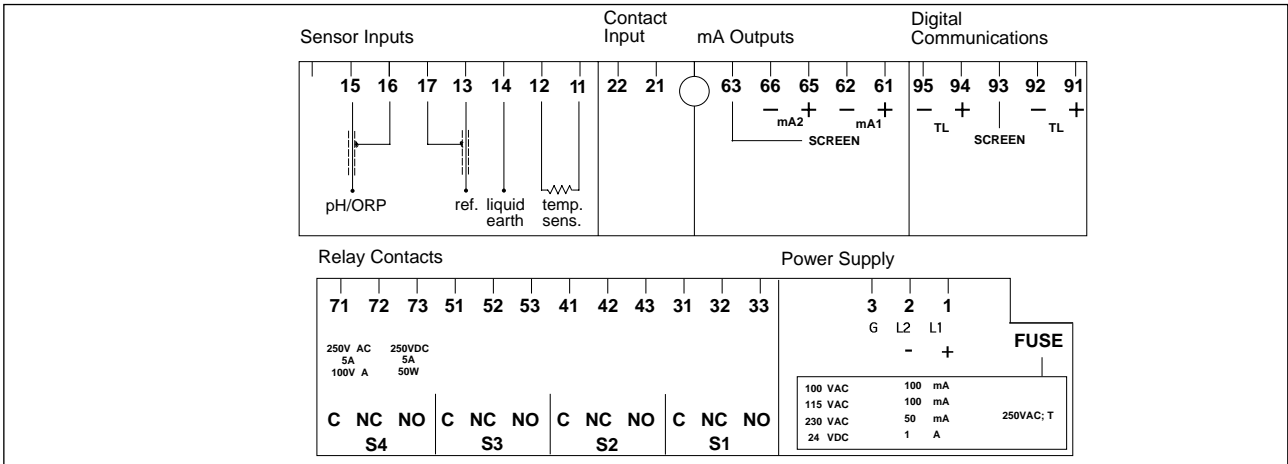

Spare parts

Part no.	Description
K1500AU	Gland set 1/2 inch for EXA's
K1541JH	Prot. plate power term. EXA400
K1541KR	/PM panelmounting for EXA400/402
K1542KW	/U pipe/wall mounting for EXA
K1543AC	Securing screw set, EXA402

Part no.	Description
K1543BK	Eprom + latest software PH402G
K1543JH	Prot. plate power term. EXA402
K1543KS	Hingepin for EXA400/402
K1543ST	/SCT for EXA400/402
K1543WM	Sparepart RS485 converter

Dimensions and Mounting

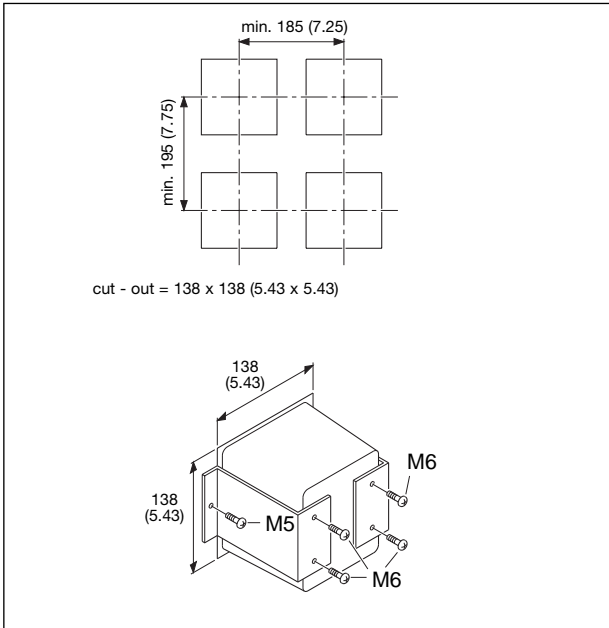

Panel cut-out and spacing

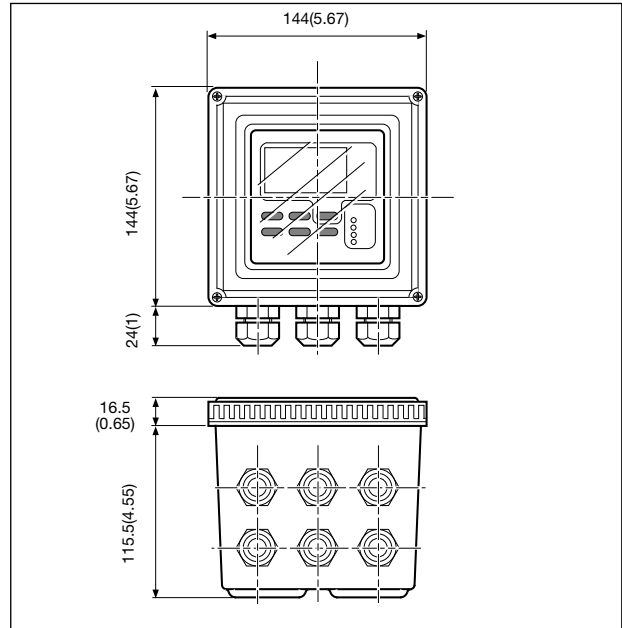

Dimensions

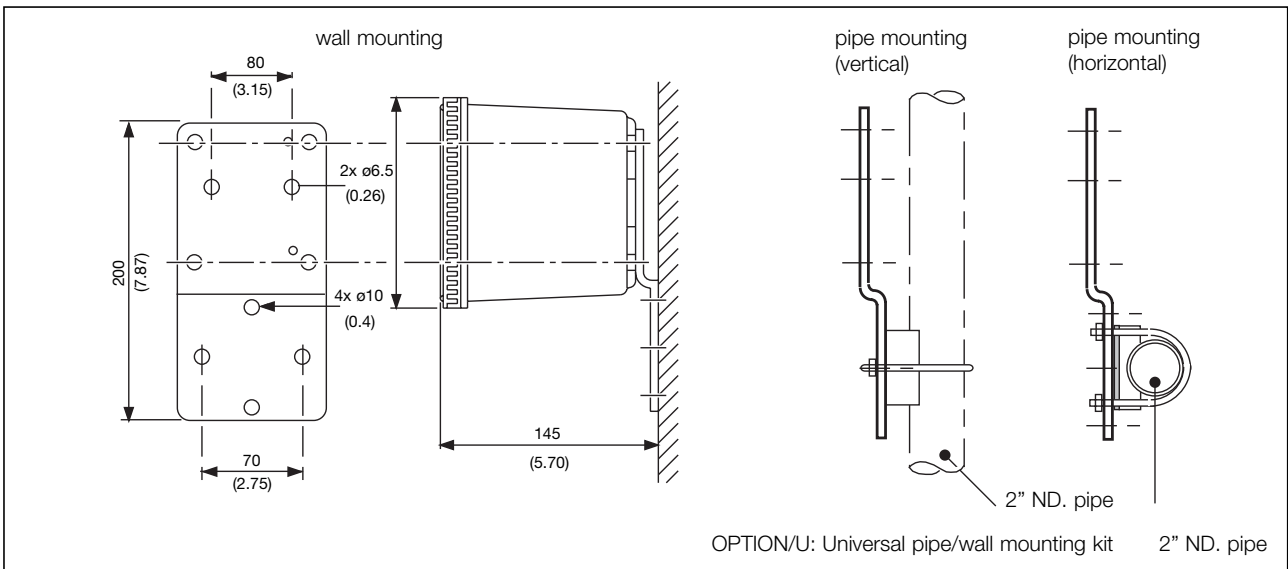

Universal pipe/wall mounting

YOKOGAWA HEADQUARTERS
 9-32, Nakacho 2-chome,
 Musashinoshi
 Tokyo 180
 Japan
 Tel. (81)-422-52-5535
 Fax (81)-422-55-1202
 E-mail: webinfo@mls.yokogawa.co.jp
 www.yokogawa.com

YOKOGAWA EUROPE B.V.
 Databankweg 20
 3821 AL AMERSFOORT
 The Netherlands
 Tel. +31-33-4641 611
 Fax +31-33-4641 610
 E-mail: info@nl.yokogawa.com
 www.yokogawa.com/eu

YOKOGAWA CORPORATION OF AMERICA
 2 Dart Road
 Newnan GA 30265
 United States
 Tel. (1)-770-253-7000
 Fax (1)-770-251-2088
 E-mail: info@yca.com
 www.yokogawa.com/us

YOKOGAWA ELECTRIC ASIA Pte. Ltd.
 5 Bedok South Road
 Singapore 469270
 Singapore
 Tel. (65)-241-9933
 Fax (65)-241-2606
 E-mail: webinfo@yas.com.sg
 www.yokogawa.com/sg

Yokogawa has an extensive sales and distribution network. Please refer to the European website (www.yokogawa.com/eu) to contact your nearest representative.



YOKOGAWA ◆