

# General Specifications

## Hamilton Industrial Electrodes for pH/Redox

When you purchase an analyzer system from Yokogawa, you know you are getting the ultimate technology fit for your purpose. Because Yokogawa is a global leader in analyzer technology based on an outstanding track record of continuous innovation. And now Yokogawa has signed a Global Preferred Vendor Agreement with the Hamilton Company a world leader in sensor technology.

This agreement is to supply sensors to meet the stringent requirements of the pharmaceutical and biotechnology industries and in food production processes such as fermentation.

### Hamilton Company

The Hamilton Company is a global enterprise with a long track record in fluid measurement. For over 50 years, Hamilton has been using quality materials and skilled workmanship and has a life-long commitment to precision, accuracy and quality. The Sensor Technology Group designs and manufactures sensors for the measurement of pH, temperature, conductivity, and dissolved oxygen. These sensors have a well-established reputation for long-life and fast stable readings in both laboratory and in-line process applications.

### Vigilance

Our agreement with Hamilton as Global Preferred Vendor for state-of-the-art sensors is in line with Yokogawa's strategy as a vigilant supplier and our commitment to leading edge technology. The combined expertise of Yokogawa and Hamilton ensures that your total analyzer systems give accurate, reliable performance. Because we have subjected the Hamilton sensors in combination with our analyzers to rigorous testing under different operating conditions. By joining forces, we offer you world-class technologies in the one system, giving top class performance.



### Features

- Includes the new analytical Instrumentation standard: Variopin connector
- Autoclavable and Sterilisable pH sensors
- Build-inn temperature sensor when Variopin type connector is selected
- Sensors and fittings complement Yokogawa products
- Sensors qualify fully for Biotechnology, Pharmaceutical and food production applications
- Sanitary fittings
- Autoclavable electrode for biotechnology, pharmaceutical and chemical applications
- ATEX certified sensors and fittings
- Certificate downloadable from [www.hamiltoncompany.com](http://www.hamiltoncompany.com)

### System configuration

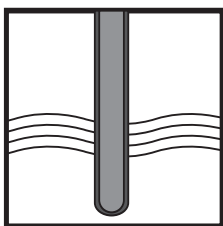

Sensors

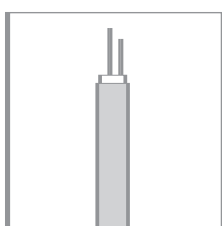

Cables

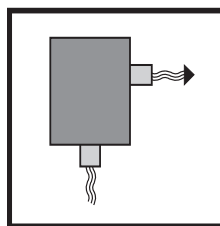

Fittings

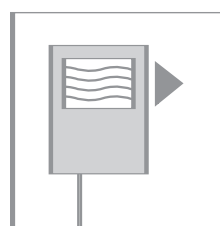

Transmitters

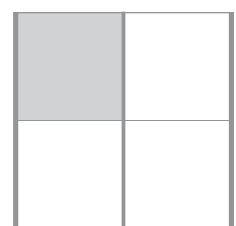

Accessories

## Combined pH electrodes (Flow)

Both sensors have a special reference system called the EVER-F. The AgCl reservoir is separated from the reference electrolyte by a diffusion distance preventing poisoning of the reference system and keeping the Ag in the reference system, avoiding black ceramics. These sensors fit into most common pressurizable armatures for electrodes with a reservoir diameter of about 30 mm.

### Features Chemotrode

- Temperature range 0-130°C
- Steam sterilizable
- High Quality Ag/AgCl reference system
- Maximum pressure : 6 bar
- pH range 0-14

| Part No.  | Description    |
|-----------|----------------|
| 10/238760 | Chemotrode 120 |
| 10/238762 | Chemotrode 150 |

### Additional characteristics of Chemotrode P

- Long life-time in protein containing and partially organic solutions
- 3 high performance ceramic junctions for lower risk of blocking
- Refillable with Protelyte electrolyte
- Precise pH measurement using electrolyte pressurized with air

| Part No.  | Description      |
|-----------|------------------|
| 10/238761 | Chemotrode P 120 |
| 10/238763 | Chemotrode P 150 |

### Additional characteristics of Chemotrode Bridge

- Build in Pt100 in VP Version
- One platinum single pore diaphragm for clog-free operation
- Refillable with Skylyte electrolyte
- Suitable for harsh applications where there is a possible of poisoning

| Part No.  | Description             |
|-----------|-------------------------|
| 10/238753 | Chemotrode Bridge VP120 |
| 10/238754 | Chemotrode Bridge VP150 |
| 10/238770 | Chemotrode Bridge 120   |
| 10/238772 | Chemotrode Bridge 150   |

**Note:** The ATEX certificate is downloadable from the Hamilton website: [www.hamiltoncompany.com](http://www.hamiltoncompany.com)



Chemotrode Bridge VP

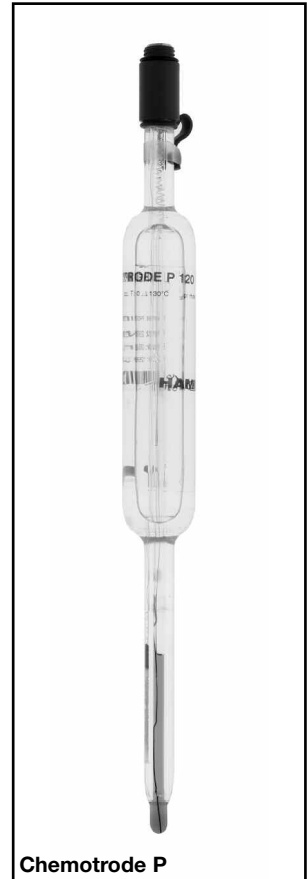

Chemotrode P

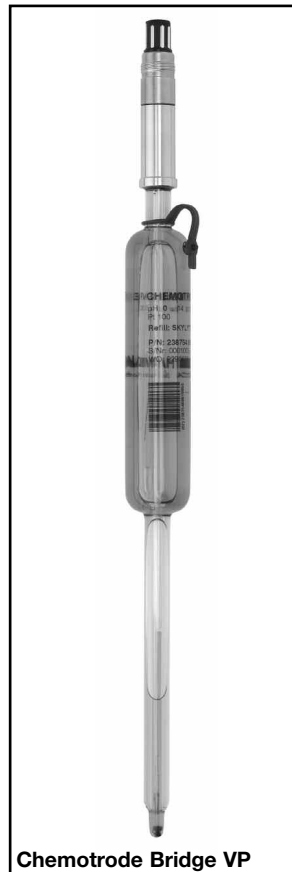

Chemotrode Bridge VP

### Combined pH electrodes (Non-flow)

The non-flow type sensors are filled with a polymer electrolyte which can be used from pH 0-14 and can withstand temperatures from -10° to 130°C. This high temperature rating also means that these sensors are also steam sterilizable.

#### Features

- Very stable readings in most ion weak solutions
- range 0 to 14 pH
- All sensors available with DIN and VP connector
- Built-in temperature sensor (VP version)

#### Additional characteristics of Polilyte Pro (VP)

- Suitable for samples containing solids, bacteria or sludge as well as normal drinking water
- Maximum pressure: 6 bar
- Suitable for process temperatures from -10°C up to 60°C
- Pt1000 in VP-version
- Stable measurement in low-conductive solutions

| Part no.  | Description         |
|-----------|---------------------|
| 10/238411 | Polilyte PRO 120    |
| 10/238417 | Polilyte PRO VP 120 |

#### Additional characteristics of Polilyte HT(VP)

- Up-side down mounting with VP-type possible
- Steam sterilizable and autoclavable
- Withstands continuous high process temperatures
- Maximum pressure: 6 bar at 130°C
- Suitable for high alkali processes

| Part no.  | Description       |
|-----------|-------------------|
| 10/238431 | Polilyte HT 120   |
| 10/238432 | Polilyte HT 225   |
| 10/238428 | Polilyte HTVP 120 |
| 10/238429 | Polilyte HTVP 225 |

#### Additional characteristics of Polyclave (VP)

- Maximum pressure: 6 bar
- Maximum temperature 130°C
- Withstands CIP, steam sterilizable and autoclavable
- Pt100 in VP-version
- Up-side down mounting with VP-type possible

| Part no.  | Description   |
|-----------|---------------|
| 10/238450 | Polyclave 120 |
| 10/238452 | Polyclave 170 |
| 10/238453 | Polyclave 200 |
| 10/238451 | Polyclave 225 |

#### Additional characteristics of Easyferm plus (VP)

- Withstands CIP, steam sterilizable and autoclavable
- Pt100 in VP-versions
- High performance coatramic diaphragms prevent clogging due to proteins
- Maximum: 6 bar at 135°C

| Part no.  | Description       |
|-----------|-------------------|
| 10/238643 | Easyferm Plus 120 |
| 10/238679 | Easyferm Plus 160 |
| 10/238644 | Easyferm Plus 225 |
| 10/238645 | Easyferm Plus 325 |



Polilyte Pro



Polilyte HTVP



Polyclave



Easyferm plus VP

**Additional characteristics of Mecotrode (VP)**

- 3 High performance ceramic diaphragms
- Specially suitable for applications with a higher pH or higher temperatures
- Maximum: 6 bar at 130°C
- Maximum: 6 bar at 25°C

| Part no.  | Description            |
|-----------|------------------------|
| 10/238801 | Mecotrode 120          |
| 10/238437 | Mecotrode 120 Pt100 VP |
| 10/238806 | Mecotrode 225          |

**Additional characteristics of Features Fermotrode**

- Maximum pressure: 400 kPa (4 bar at 130°C)
- pH range 2-12
- 3 high performance ceramic junctions for lower risk of blocking
- Not suitable for use in processes with citric acid or in case of frequent CIP

| Part no.  | Description    |
|-----------|----------------|
| 10/238480 | Fermotrode 120 |
| 10/238482 | Fermotrode 150 |
| 10/238484 | Fermotrode 200 |
| 10/238486 | Fermotrode 250 |

**Consumables**

| Part no.  | Description   |
|-----------|---|
| 10/238079 | HAMILTON Electrolyte 0,1M KCl, 100 ml                             |
| 10/238939 | HAMILTON Electrolyte 3M KCl viscous, 500 ml                       |
| 10/238036 | HAMILTON Electrolyte 3M KCl, 100 ml                               |
| 10/238936 | HAMILTON Electrolyte 3M KCl, 500 ml                               |
| 10/238931 | HAMILTON Storage Solution, 500 ml                                 |
| 10/238038 | Protelyte, 100 ml (Fermotrode)                                    |
| 10/238037 | Skylite, 100 ml (Chemotrode)                                      |
| 10/238937 | Skylite, 500 ml (Chemotrode)                                      |
| 10/238290 | Cleaning Solution Set<br>(2x500mL A+B + 1x500mL Storage Solution) |
| 10/238317 | DURACAL Buffer pH 4.01 250 ml                                     |
| 10/238217 | DURACAL Buffer pH 4.01 500 ml                                     |
| 10/238917 | DURACAL Buffer pH 4,01 3 x 500 ml                                 |
| 10/238318 | DURACAL Buffer pH 7.00 250 ml                                     |
| 10/238218 | DURACAL Buffer pH 7.00 500 ml                                     |
| 10/238918 | DURACAL Buffer pH 7,00 3 x 500 ml                                 |
| 10/238319 | DURACAL Buffer pH 9.21 250 ml                                     |
| 10/238219 | DURACAL Buffer pH 9.21 500 ml                                     |
| 10/238919 | DURACAL Buffer pH 9.21 3 x 500 ml                                 |
| 10/238321 | DURACAL Buffer pH 10.01 250 ml                                    |
| 10/238223 | DURACAL Buffer pH 10.01 500 ml                                    |
| 10/238923 | DURACAL Buffer pH 10,01 3 x 500 ml                                |
| 10/238228 | HAMILTON Redox-Buffer 271 mV 500 ml                               |
| 10/238227 | HAMILTON Redox-Buffer 475 mV 500 ml                               |
| 10/238322 | HAMILTON Redox-Buffer 475 mV 250 ml                               |

**Mecotrode VP****Fermotrode**

## Armatures for Industrial Applications

### Retractofit and retractomatic

This armature allows the user to install maintenance-free electrodes in critical processes. The main advantage of this design is that the sensor can be withdrawn while the process is running (i.e. for cleaning, calibration or even to replace the electrode), without interrupting the process. The armature is very easy to use and maintain. Two tube connectors allow access to the rinsing chamber. A closed insertion tube converts these armatures a sampling system for diverse applications. Both accessories can easily be exchanged for the standard insertion tube using only gentle hand pressure.

### Additional features Retractofit

- For sensors with shaftlength 210 to 225 mm
- An integral safety mechanism prevents the armature from being inserted into the sample without an electrode installed.
- Only one press of the red button is needed to move the electrode into or out of the process. All o-rings are easily replaced without special tools.
- A shortened insertion tube that allows use of the armature in narrow bore pipes for which the standard insertion tube is too long.
- Designed for applications in the chemical and waste water industry.
- All wetted steel parts are replaced by PEEK with the Petrofit PEEK

### Additional features Retractofit Bio

- This armature is designed for applications where sanitary concerns are critical.
- The armature is steam sterilizable and autoclavable.
- The SS DIN 1.4435 (SS 316) and the FDA approved EPDM O-rings withstand typical CIP cleanings.
- Check with your dealer for the right O-ring position or weld-in socket!

### Additional features Retractable

- Powerful 24 VDC drive
- Controlled from a simple time switch to a computerized process control system such as PLC's
- In the retracted position, the electrode is retained in a chamber where it can be kept moist, cleaned and even calibrated.
- Two switches for reporting electrode position or for control of external instruments (pumps, magnetic valves)
- Fixed cable length 5 m.

| Part no.  | Description  |
|-----------|--|
| 10/237202 | Weld-In Socket 15°, for armatures with o-ring at 25 mm |
| 10/237230 | Blind Plug for Weld-In socket                          |
| 10/237338 | Service Kit for Flexifit Bio & Retractofit Bio         |
| 10/237239 | Service Kit for Retractofit & Retractable              |
| 10/237339 | Kalrez Kit for Retractofit , Retractable & Retractable |
| 10/237240 | RETRACTOFIT  |
| 10/237252 | Pressure Adapter                                       |
| 10/237255 | Insertion tube short for Retractofit/-matic            |
| 10/237260 | RETRACTOMATIC  |
| 10/237278 | Insertion tube closed for Retractofit/-matic           |
| 10/237290 | Service Kit for Retractable                            |
| 10/237440 | RETRACTOFIT BIO  |



Retractofit (PEEK)



Retractofit Bio



Retractable

## Masterfit and retractomaster

Suitable for applications where high accuracy or long-term stability is required in conjunction with liquid electrolyte electrodes. Such electrodes must be pressurized to ensure flow of the electrolyte solution. The retractable version can be used when cleaning or recalibration during the process is desirable.

The armatures allow electrodes to be mounted on pipe work or tanks with a weld-in socket. There are no awkward flat seals for sealing the armature. Large windows allow visual inspection of the electrolyte level in the installed electrode. Both armatures have an integrated manometer into the housing to easily check for the pressure. All O-rings are easily replaced without special tools.

### Additional feature Masterfit

- Temperature range: -10°C to 130°C
- Maximum pressure: 6 bar
- Suitable for all electrodes with electrolyte reservoir with shaft length 250mm.
- Mechanical connection 1 1/4"
- Fitted with a tension lever that allows a slow release of the pressure
- Three stainless steel pins protect the electrode tip from damage
- Available in three insertion depths for vessels or fermenters of different wall thicknesses.

| Part no.     | Description   |
|--------------|---|
| 10/237200-OP | MASTERFIT 120   |
| 10/237225-OP | MASTERFIT 150   |
| 10/237235    | MASTERFIT 200   |
| 10/237245    | MASTERFIT 250   |
| 10/237252    | Pressure Adapter  |
| 10/237320    | FlexiFlange (1-1/2" fange, wetted parts PTFE)                 |
| 10/237910    | FlangeAdapter for Masterfit 120 with 150'-a-length electrodes |
| 10/237229    | Service Kit for Masterfit                                     |
| 10/237319    | Kalrez Kit for Flexifit & Masterfit                           |

### Additional feature Retractablemaster

- Suitable for applications in which liquid electrolyte electrodes must be used and cleaning or recalibration during the process is desirable.
- The armature is very easy to use and maintain. Only one press of the red button is needed to move the electrode into or out of the process.
- In the retracted position, the electrode is retained in a chamber where it can be kept moist, cleaned and even calibrated. This can all be done without process interruption or disassembly of the armature. Two tube connectors allow access to the rinsing chamber.

| Part no.  | Description  |
|-----------|--|
| 10/237255 | Insertion tube short for Retractablefit/-matic         |
| 10/237278 | Insertion tube closed for Retractablefit/-matic        |
| 10/237930 | Flange flowthrough cell PFA                            |
| 10/237202 | Weld-In Socket 15°, for armatures with o-ring at 25 mm |
| 10/237230 | Blind Plug for Weld-In socket                          |



\*Please specify the desired O-ring position (OP) in your order.

## Sanitary Non-Retractable Armatures

Maintenance-free sensors with a standard 12 x 120 mm design and PG 13.5 thread will fit perfectly.

Steam sterilizable, autoclavable and CIP compatible cleaning are possible with the sanitary design. The materials used are SS DIN 1.4435 (SS 316) and the EPDM O-rings are FDA approved.

### Additional features Flexifit VV

- Temperature range: -10°C to 130°C
- Maximum pressure: 6 bar
- Suitable for Tuchenhagen VARIVENT sanitary process connections.
- The 15° version might be used for classic sensors with the need for vertical mounting of the connector head
- The 0° version is ideal when using HAMILTON electrodes for up-side-down mounting

### Additional features Flexifit TC

- Designed for mounting on TriClamp 1.5" process connections.
- The short immersion depth makes this armature perfect for small flow-through cells.
- Good sensor protection with 3 protection rods

### Additional features Flexifit Bio

- G1 1/4" process connection
- The surface quality is N5 (Ra = 0.4 µm) electropolished.
- The armature comes with a material certificate.
- Good sensor protection with 3 protection rods
- Good sanitary design (easy cleaning and no sensor clogging).

### Additional features Flexi Flow SL 10

- Flowthrough armature
- Swagelok process connectors
- Materials: D1.4435 and O-rings of FDA-EPDM

| Part No.     | Description  |
|--------------|--|
| 10/237202    | Weld-In Socket 15°, for armatures with o-ring at 25 mm                       |
| 10/237219    | Service Kit for Flexifit   |
| 10/237230    | Blind Plug for Weld-In socket  |
| 10/237331-OP | FLEXIFIT BIO   |
| 10/237338    | Service Kit for Flexifit Bio & Retractable Bio                               |
| 10/237340    | FlexiFlow SL 10 (flow cell for 120 mm sensors with 10mm Swagelok connectors) |
| 10/237344    | FLEXIFIT VV-0  |
| 10/237345    | FLEXIFIT VV-15   |
| on request   | FlexiFit BIO 225   |
| on request   | FlexiFit BIO 325   |

\* Please specify the desired O-ring position (OP) in your order.



Flexi Fit VV-0



Flexi Fit VV-15

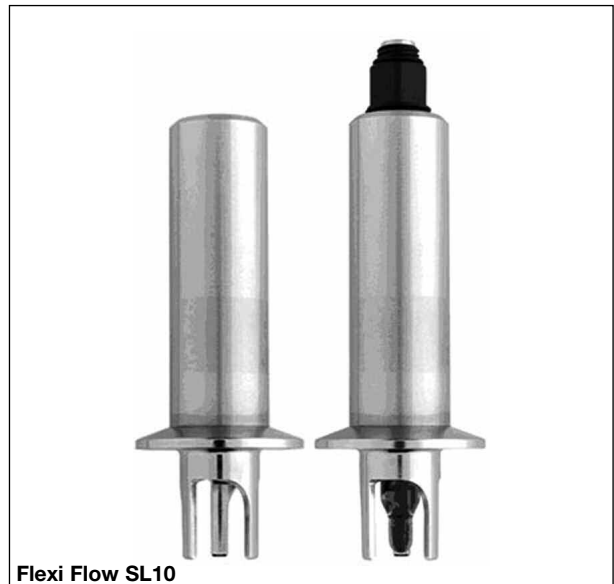

Flexi Flow SL10

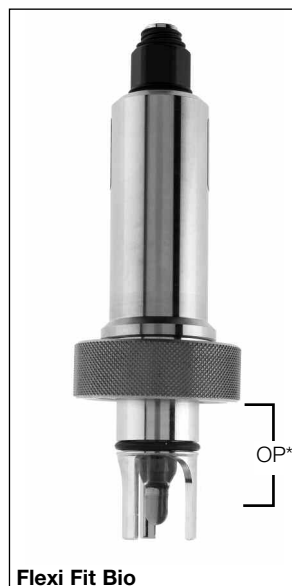

Flexi Fit Bio



Flexi Flow SL 10

## Cables for Industrial Applications, type WU20D

When you need optimal pH or Redox measuring results, the complete measuring loop not only requires highly qualified sensors and transmitters but also the special purpose sensor cables.

The program of Yokogawa includes a range of high quality, low-noise cables for accurate transmission of low voltage signals even in areas where interference is present. They have a shield with an internal anti-noise sheath and can be connected to all pH and ORP (Redox) electrodes fitted with an O-connector. At the electrode end the cables are provided with a socket having spring gilded contacts for secure connection to the sensor. The combination electrode plug and cable socket is watertight and temperature resistant up to 125°C. It meets the requirements of IP 65.

### Features

- Internal anti-noise sheath for accurate measurement.
- Gold plated spring O-connectors parts, for good electrical contact under the most severe conditions.
- Coaxial plug and socket with watertight sealing that meets the requirements of IP 65.
- Cables for industrial appl. and for laboratory use are available.

### Coax Cables

These cables are for connecting to **single or combined** sensors fitted with an O-plug. For use at higher temperature specifications (up to 110°C continuously or 125°C for short times) and the most severe conditions.

### Triax Cables

These cables are for connecting to **combined** sensors fitted with an O-plug or to **single** sensors with an O-plug for use in areas where electrical interference is present. They have both inner, and outer shielding. In areas where electrical interference is likely we recommend to use the Triax electrode cable type WU20D-LT, marked with a blue strip.

### Notes:

1. For industrial applications the cables can be colour coded with the following marks:
  - Measuring electrode: red
  - Reference electrode: yellow
  - Temperature electrode: green
  - Combined electrode: blue

Adhesive markers are provided for this purpose and should be fitted to both ends of the cables.
2. To secure optimal conditions, the cables may not be damaged or shortened. For protection of the cables there are special hoses available of 5 or 10 mtr. (K1500CJ, K1500CK respectively)
3. Suitable for use in intrinsically safe areas.

### Specifications

|                         |   |
|-------------------------|---|
| <b>Bending radius</b>   | : min. 50 mm                                      |
| <b>Max. temperature</b> | :   |
| - type WU20D-PC         | : 110°C (continuously)<br>125°C (for short times) |
| - type WU20D-LT         | : 70°C (continuously)                             |
| <b>Wire connections</b> | : 2 mm contact pins                               |

| Model       | Suffix code | Description     |
|-------------|-------------|-----------------|
| WU20D       |             | Electrode cable |
| Type        | -PC         | COAX            |
|             | -LT         | TRIAX           |
| Length in m | 01          | 1 mtr           |
|             | 02          | 2 mtr           |
|             | 05          | 5½ mtr          |
|             | 10          | 10 mtr          |
|             | 15          | 15 mtr          |
|             | 20          | 20 mtr          |
|             | 25          | 25 mtr          |

GS 12B6J5-E-E

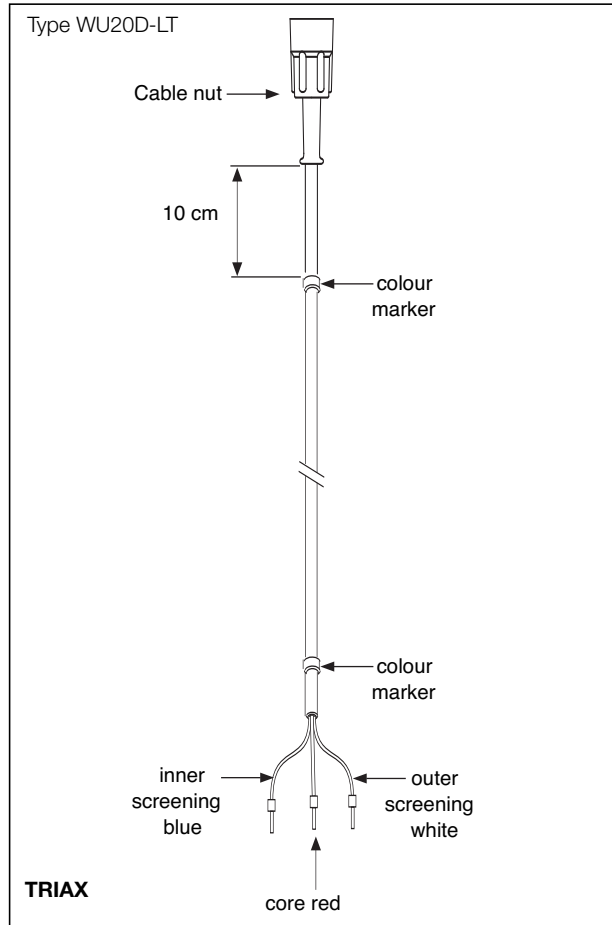
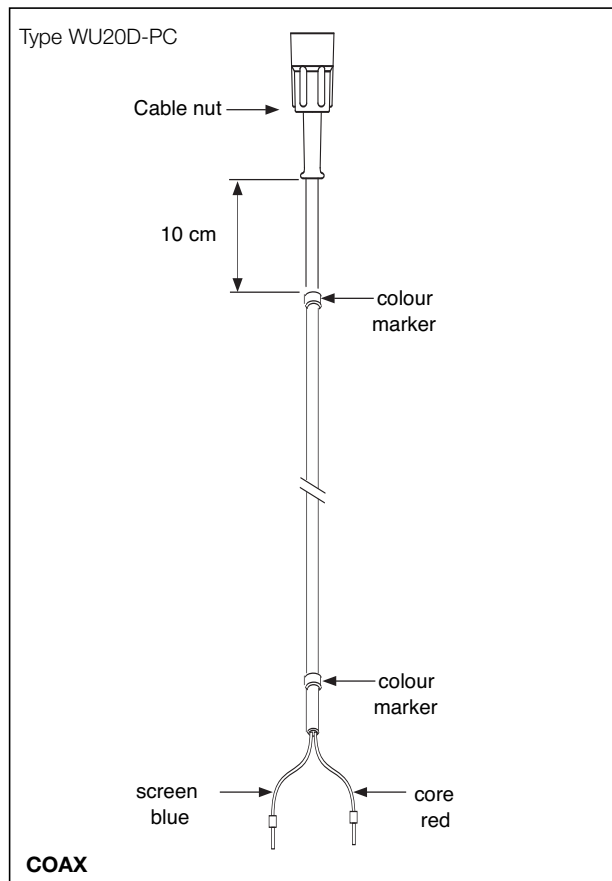

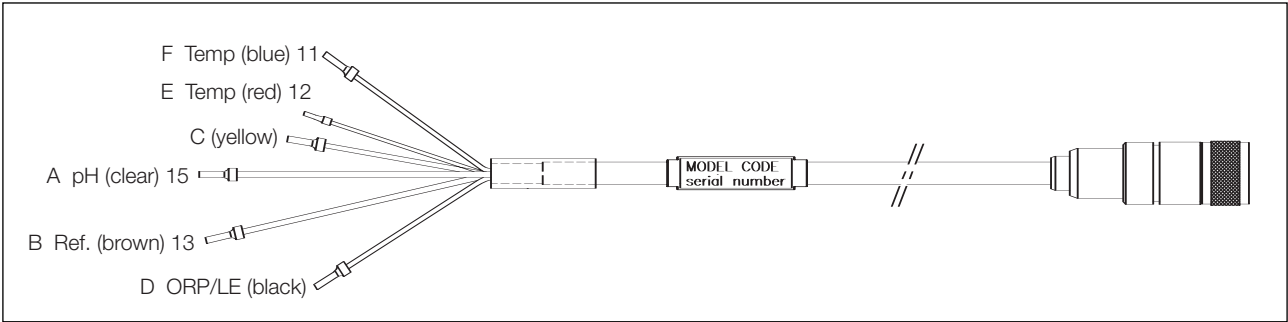

**Dimensions FU20**

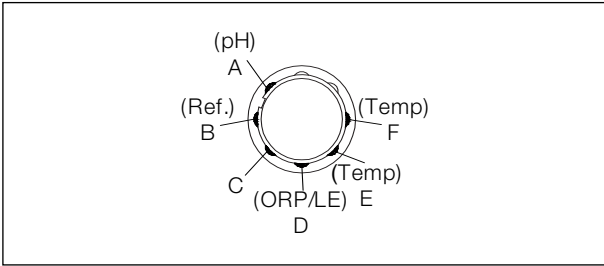

**Connector lay out**

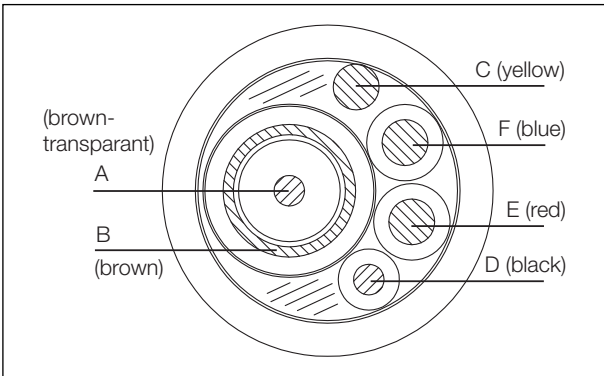

**Cable lay out**

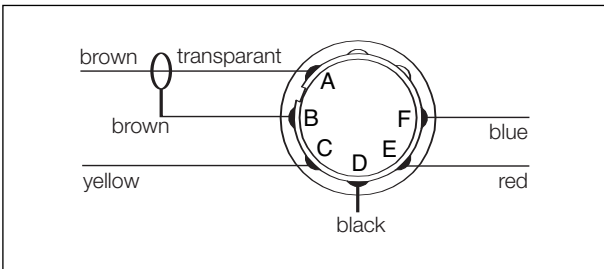

**Connector wiring**

**Model and Suffix codes**

| Model          | Suffix Code | Description            |
|----------------|-------------|------------------------|
| WU10           |             | Universal sensor cable |
| Connector type | -V          | Variopin               |
| Cable type     | -S          | Single Coax            |
| Cable length   | -03         | 3 meters               |
|                | -05         | 5 meters               |
|                | -10         | 10 meters              |
|                | -15         | 15 meters              |
|                | -20         | 20 meters              |

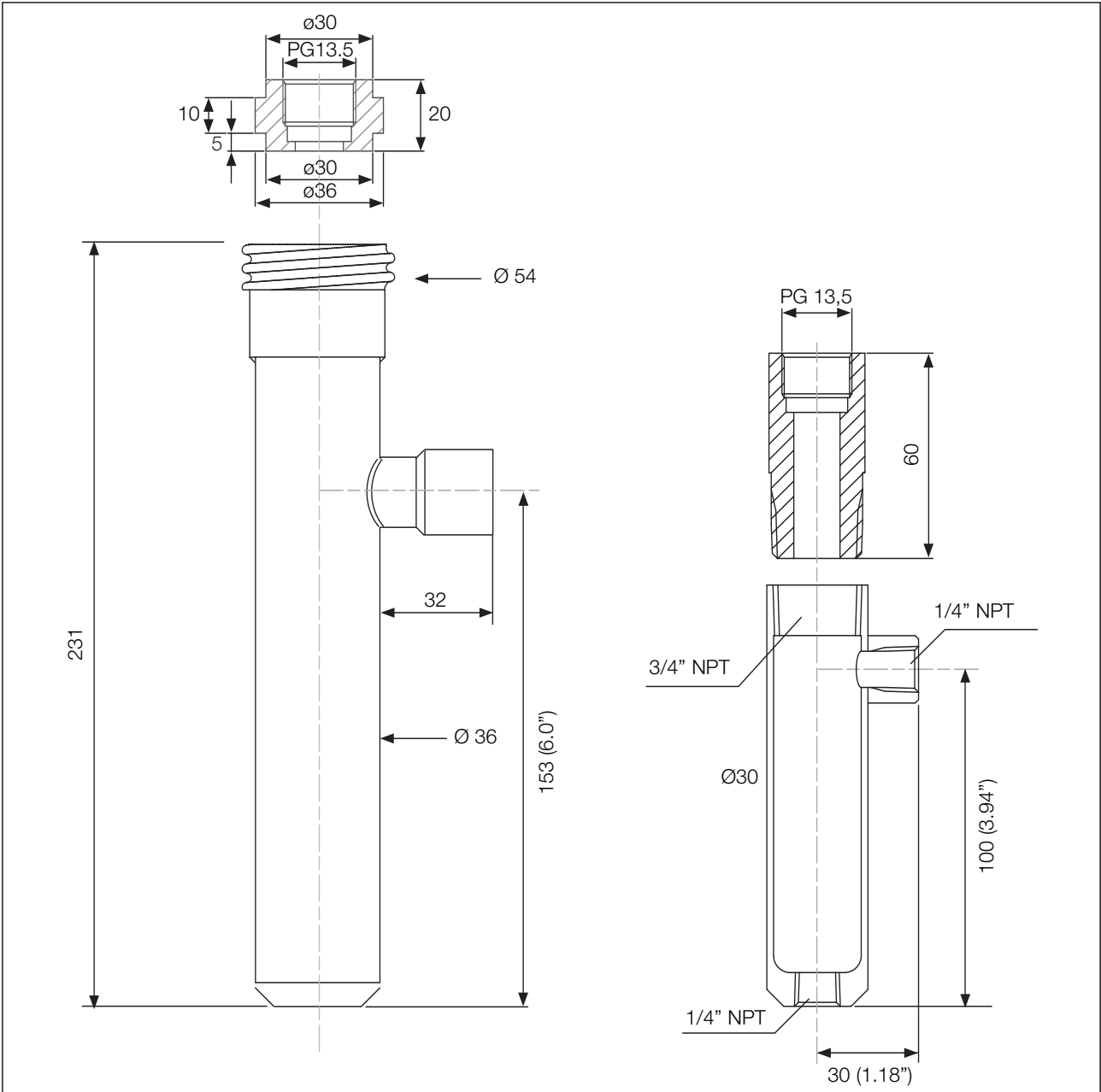

**Flow fitting FF40  
with K1523JA: Adapter to fit sensors with a  
PG13,5 process connection in FF40/FS40 and  
FD40 fittings. Material: Polypropylene**

**Flow fitting option /FF K1598AC  
(incl. 3.1 B certificate)  
with Adapter K1598AB to fit sensors with  
PG13,5 process connection**



**YOKOGAWA HEADQUARTERS**

9-32, Nakacho 2-chome,  
Musashinoshi  
Tokyo 180  
Japan  
Tel. (81)-422-52-5535  
Fax (81)-422-55-1202  
[www.yokogawa.com](http://www.yokogawa.com)

**YOKOGAWA EUROPE B.V.**

Databankweg 20  
3821 AL AMERSFOORT  
The Netherlands  
Tel. +31-33-4641 611  
Fax +31-33-4641 610  
[www.yokogawa.com/eu](http://www.yokogawa.com/eu)

**YOKOGAWA CORPORATION OF AMERICA**

2 Dart Road  
Newnan GA 30265  
United States  
Tel. (1)-770-253-7000  
Fax (1)-770-251-2088  
[www.yokogawa.com/us](http://www.yokogawa.com/us)

**YOKOGAWA ELECTRIC ASIA Pte. Ltd.**

5 Bedok South Road  
Singapore 469270  
Singapore  
Tel. (65)-241-9933  
Fax (65)-241-2606  
[www.yokogawa.com/sg](http://www.yokogawa.com/sg)

Yokogawa has an extensive sales and distribution network. Please refer to the European website ([www.yokogawa.com/eu](http://www.yokogawa.com/eu)) to contact your nearest representative.

**YOKOGAWA** ◆