

General Specifications

Model FC20
Cleaning Systems Chemical-,
mechanical cleaning systems

pH/ORP

For industrial applications and particularly for automatic process measurements it is of the greatest importance that the sensitive part of a glass electrode and the diaphragm of a reference electrode are kept clean.

Often it is not practical to interrupt a process for cleaning the electrodes, an accurate indication is required over a long period, replacing the electrodes is difficult, etc. Then an automatic cleaning mechanism may be the solution.

Yokogawa manufactures two different cleaning systems for pH and/or ORP (Redox) measurements:

- Chemical cleaning.
- Mechanical cleaning.

The cleaning elements have standardised dimensions for mounting in flow-, insertion and immersion fittings.

Features

- Designed for in-line electrode cleaning in flow- and immersion fittings of Yokogawa.
- Restricts sediment formation on the electrodes and increases the period between calibrations.
- Optimum cleaning effect.
- Standardised dimensions for mounting in an electrode hole of a fitting.



System Configuration

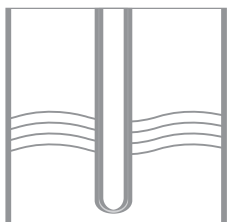

Sensors

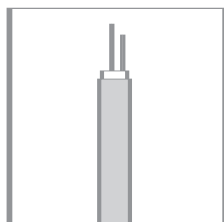

Cables

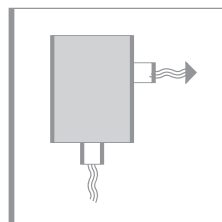

Fittings

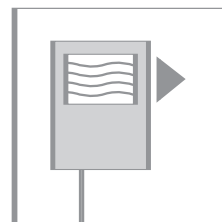

Transmitters

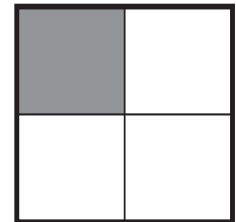

Accessories

Chemical cleaning system

The chemical cleaning system is effective in processes where deposits can be removed by a suitable solvent. Good cleaning effects can be obtained from periodically spraying of an electrode. EXA PH402 has a built-in wash timer with programmable wash time, interval time and relaxation time for automatic cleaning of the electrodes, preventing pollution of the pH sensitive parts. After washing, it is possible to check the response time of the electrodes.

A built-in (no return) nozzle in the spray unit prevents penetration of the process liquid in the cleaning system.

The standardised dimensions allow mounting in all flow-, insertion- and immersion fittings of Yokogawa as well as back-end mounting on the 4-in-one pH/Redox electrodes.

Features

- The EXA pH402 analyzer has a built-in timer and HOLD circuit.
- Built-in (no return) nozzle to prevent penetration of the process liquid into the cleaning system.

Specifications

Materials

Nozzle	: Hastelloy
O-rings	: EPDM rubber
Mounting set	: PVDF/Stainless steel
Tubing	: 1/4" (OD Ø) PVDF/Nylon tubing
Process cond.	: Max. 1 MPa (10 bar) at 100°C

Mounting

K1547PA	: /HCN2, 2-hole flow-, insertion fitting (PH20)
K1547PA	: /HCN3, 3-hole flow-, insertion-, immersion fitting
K1547PB	: /HCN4, 4-hole flow-, insertion-, immersion fitting
K1547PJ	: /HCNF, back-end mounting on FU20/PH20

Brush cleaning system

The brush in this cleaning system periodically strikes along the sensitive membrane of the measuring electrode, so that this part is wiped frequently, preventing sediment formation on it.

The flow of measuring solution is not obstructed and interruption of measurement during cleaning is not necessary.

The brush cleaning system is activated electrically or pneumatically.

The standardised dimensions allow mounting in the (4-hole) flow- and immersion fittings of Yokogawa.

Features

- Minimum maintenance by static sealing of brush movement.
- Pneumatically or electrically driven.
- Easy replaceable brush.
- Brush height adjustable for optional cleaning effect.

Specifications Brush holder

Material

Body (see figure 2)	: a. Stainless steel AISI 316 b. Epoxy c. Silicone rubber d. Epoxy resin
Brush	: Horse hair (in PVDF holder)
Process conditions	: Max. 1 MPa (10 bar) at 100°C
Weight	: Approx. 120 g
Mounting	: In flow- and immersion fittings (4-hole) of Yokogawa
Wetted parts	: PVDF, Silicon, Viton, Epoxy

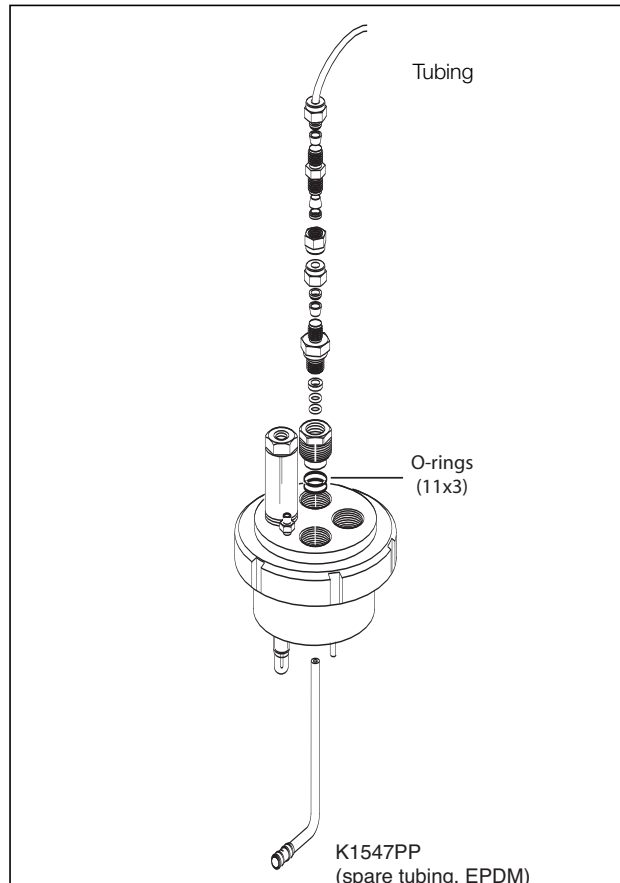

Fig. 1. Chemical cleaning system

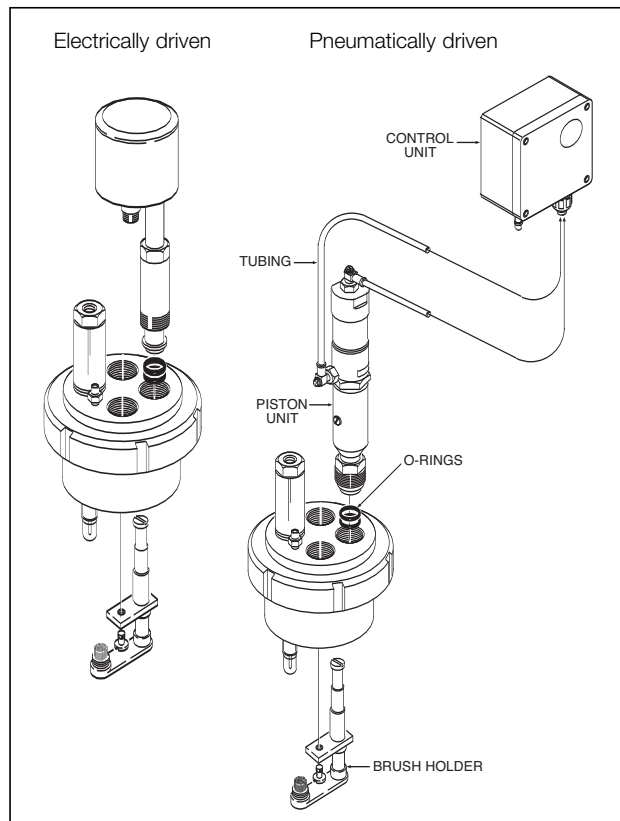

Fig. 2. Electrically/pneumatically driven brush cleaning

Driving mechanism (electrical)

Supply

- Voltage : 24 V AC ($\pm 10\%$);
for 10 V/220V AC a power supply,
type BC10 is available
- Frequency : 50/60 Hz
- Consumption : Max. 4 VA

Cleaning frequency

: 2 Strokes per minute

Angle

: Rotation of 40° (swing)

Electrical connection

: Gold plated spring O connector (for
standard cable, model WU20)
screw thread: 1/4" BSPP

Material

- Driving system : Stainless steel AISI 316
- Driving shaft : Stainless steel AISI 316
- Cap : Silicone rubber
- Connector : Polyvinylidene fluoride (PVDF)
- Mounting nut : Ryton R4

Weight

: Approx. 1 kg

Driving mechanism (pneumatical)

1. Piston unit

Air supply

: Via the connected control unit

Cleaning frequency

: 1/4 ... 2 strokes per minute
(adjustable on the control unit)

Angle

: Rotation 40°

Air connectors

(IN 1 and IN 2)

: $\varnothing 4$ mm (external)

Material

- Body : Brass
- Mounting gland : Stainless steel AISI 316

Weight

: Approx. 1 kg

2. Control unit

Air supply

: 140 kPa (1.4 bar) pressurized air

Ambient temperature range

: -10 to + 60°C

Housing

- Material : Aluminium case with chemical
resistant lacquer, IP65
- Entries : Air connector $\varnothing 6$ mm
- Dimensions : See dimensional drawings
- Mounting : Wall mounting (for fixing
dimensions see dimensional
drawings)
- Weight : Approx. 2.5 kg

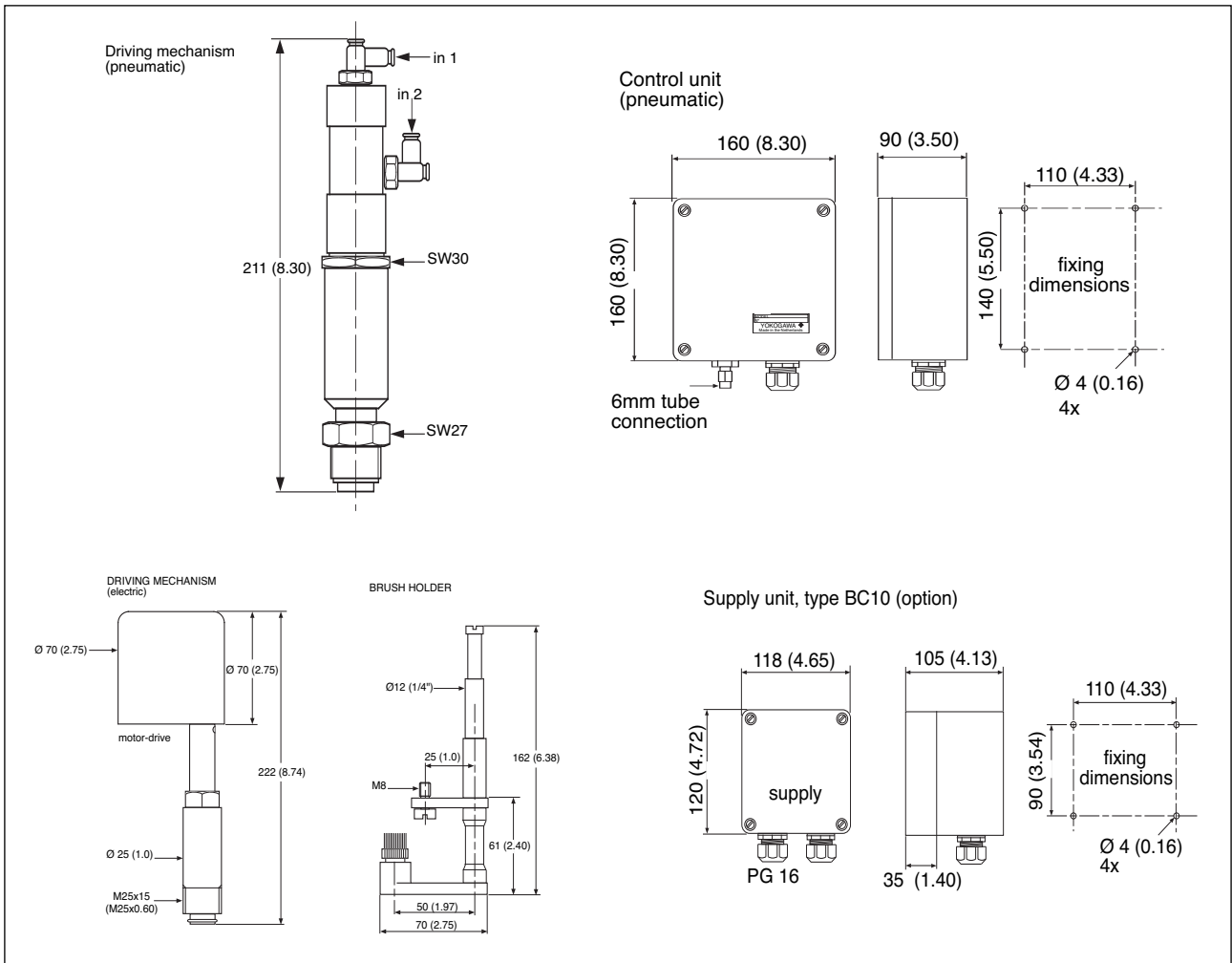

Figure 3. Dimensions

Selection criteria

Applications with:	Chemical		
	Mechanical Brush	Acid	Base
Oils, fats			
Resins (wood, pulp)			X
Emulsions of latex	X		
Fibers (paper, textile)	X		
Crystalline precipitations (carbonates)	X	XX	
Amorpheus precipitations (hydroxides)	X	XX	

Mechanical cleaning system

Model	Suffix code	Options code	Description
FC20			Cleaning system
Design	-VE		Brush cleaning (electrical driven)
	-VP		Brush cleaning (pneumatically driven)
Options		/T	10 mtr. nylon tubing 6.35 mm OD (1/4")

Chemical cleaning system

Type	Description
K1520FJ	5m tubing
K1520FK	10m tubing
K1547PA	Complete cleaning system HCN2, HCN3
K1547PB	Complete cleaning system HCN4
K1547PJ	Complete cleaning system HCNF for back-end mounting on FU20/PH20
K1547PP	EPDM spraying valve HCNX nozzle (5 sets)

Accessories and options

Type	Description
WU20-PC02	COAX-cable (2 m) for FC20-VE
WU20-PC05	COAX-cable (5,5 m) for FC20-VE
WU20-PC10	COAX-cable (10 m) for and FC20-VE
BC10	Supply unit (220/24 V AC) for motor of FC20-VE

Service parts

Type	Description
K1500BZ	O-rings Viton 11x3 (6Pcs)
K1520NA	Tubing (ø 4 mm) Brush cleaning (pneumatically driven)
K1500GR	O-ring (11 x 3) for mounting in electrode holes (8 pieces)
FP20-R12	Electrode mounting set (Ryton R4) for mounting electrode holes
K1520NB	Brush for mechanical cleaning
K1520NF	Motor unit for electrically driven brush cleaning
K1520NG	Brush holder for mechanical cleaning
K1520NH	Piston for pneumatically driven brush cleaning
K1520NJ	Control unit for pneumatically driven brush cleaning
K1547PF	Nozzle and mounting set HCN2, HCN3, HCNF
K1547PG	Nozzle and mounting set HCN4
K1547PH	Nylon tube (10 mtr) and tube mounting set for hastelloy cleaning system

YOKOGAWA HEADQUARTERS

9-32, Nakacho 2-chome,
Musashinoshi
Tokyo 180
Japan
Tel. (81)-422-52-5535
Fax (81)-422-55-1202
www.yokogawa.com

YOKOGAWA CORPORATION OF AMERICA

2 Dart Road
Newnan GA 30265
United States
Tel. (1)-770-253-7000
Fax (1)-770-251-2088
www.yokogawa.com/us

YOKOGAWA EUROPE B.V.

Databankweg 20
3821 AL AMERSFOORT
The Netherlands
Tel. +31-33-4641 611
Fax +31-33-4641 610
www.yokogawa.com/eu

YOKOGAWA ELECTRIC ASIA Pte. Ltd.

5 Bedok South Road
Singapore 469270
Singapore
Tel. (65)-241-9933
Fax (65)-241-2606
www.yokogawa.com/sg

Yokogawa has an extensive sales and distribution network.

Please refer to the European website (www.yokogawa.com/eu) to contact your nearest representative.



YOKOGAWA ◆