

General Specifications

OR400G 4-wire Type ORP Converter

EXA OR

GS 12C04C01-01E

GENERAL

The EXA OR-series 4-wire Oxygen Reduction Potential (ORP) converter OR400G is suitable for large-scale plants as well as for general measurement and control applications.

This converter can be used with not only regular OR8EFG KCl filling and OR8ERG KCl refillable electrodes but also the HA485 Xerolyt solid-electrolyte electrode, the DPA485 long-life electrode for chemical processes, and the DPAS485 steam-resistant electrode for use in small culture tanks.

Converter parameters can be set interactively from the front panel; real-time self-diagnostic functions ensure continued accuracy and reliability.

Various electrode washing methods are supported: ultrasonic washing, jet washing, and brush washing.



FEATURES

Easy to Use

- Normally you do not need to open the front panel to operate the converter. Normal day-to-day maintenance can be performed— even on rainy days —without opening the front panel.
- Output can be freely set to correspond to arbitrary input span of 100 mV or greater.
- Wash timer functions are built in.
- Parameters can be set interactively from the front panel.
- Real-time self-diagnostic functions ensure continued accuracy and reliability.

Variety of Electrodes Available

- Electrodes are available to suit a wide range of applications.

Various washing methods supported

- Ultrasonic washing for SUS316 stainless steel, titanium & Hastelloy C.
- Jet washing also supported.
- Brush washing also supported.

For the ORP electrodes, see GS 12B07B02-E.

For the holders or cleaning devices, see GS 12J5C2-E.

SYSTEM CONFIGURATION

ORP Electrodes	Holder, Holder with Cleaning system	ORP Converter	
<ul style="list-style-type: none"> ● KCl Refillable Type OR8ERG ● Xerolyt HA485 ● for Chemical DPA485 ● KCl Filling Type OR8EFG ● For Small Culture Tanks DPAS485 	<ul style="list-style-type: none"> ● Guide Pipe PH8HG ● Submersion Type Holder PH8HS No Cleaning Ultrasonic Cleaning Jet Cleaning Brush Cleaning 	<ul style="list-style-type: none"> ● 4-Wire ORP Converter OR400G 	
Accessories	<ul style="list-style-type: none"> ● Flow-Through Type Holder PH8HF No Cleaning Ultrasonic Cleaning Jet Cleaning Brush Cleaning 	<th>Cleaning Device</th>	Cleaning Device
<ul style="list-style-type: none"> OR8AX ● Sensor Stand ● Calibration Reagent and KCl Solution 	<ul style="list-style-type: none"> ● Ultrasonic Oscillator PUS400G 		

System.EPS

SPECIFICATIONS

1. OR400G ORP Converter

Measuring range: -1500 to +1500 mV
 Display: digital (LCD), range -1500 to +1500 mV
 Converter output: 4 to 20 mA DC, isolated (floating),
 maximum load resistance 600Ω.

Converter range: output may be set to correspond to an arbitrary input span of at least 100 mV. (Shipping-time default is for output to correspond to -1500 to +1500 mV measuring range).

Contact output:

Contact output function that can be set

Contact	Function	
	Setting (freely selectable)	Operation (freely selectable)
S1	OFF, Low limit, High limit, HOLD	ON/OFF
	OFF, Low limit, High limit, HOLD	Ditto
S2	OFF, Low limit, High limit, HOLD	Ditto
	OFF, Low limit, High limit, HOLD, Cleaning timer, Hi-Hi limit, Lo-Lo limit	Ditto
FAIL	Failure	ON/OFF

T02C.EPS

Contact ON/OFF

(a) S1, S2, S3

Action	Power		
	ON	Closed	Open
	ON	Closed	Open
	OFF	Open	Open

(b) FAIL

Action	Power		
	ON	Closed	Open
	ON <td>Closed</td> <td>Closed</td>	Closed	Closed
	OFF	Open	Open

T02D.EPS

When closed, each indicator lamp is lit corresponding to each contact status.

Contact type: Relay contact output *dry contact

Contact rating

250 V AC, 2 A, Max. 100 VA

220 V AC, 2 A, Max. 50 W

Contact input: Supports manual starting of auto-wash functions.

Power supply voltage: 88 to 132V AC or 176 to 264V AC at 50/60Hz.

Power consumption: approx. 8.5VA

Operating temperature: -10 to 55°C

(hood may be fitting as option)

Operating humidity: 10 to 90 % RH

Storage temperature: -30 to 70°C

Construction: Watertight complying with JIS C0920, equivalent to NEMA 4 water proof construction

Materials:

Case: Aluminum alloy casting

Cover and window: Polycarbonate

Finish: Baked polyurethane resin coating

Color:

Cover: Deep sea moss green (Munsell 0.6GY3.1/2.0 equivalent.)

Case: Frosty white (Munsell 2.5Y8.4/1.2 equivalent.)

Mounting: 50A dia. vertical or horizontal pipe, wall, rack or panel.

Electrical connections:

ORP sensor: 13.5mm dia. hole (plastic gland, watertight to JIS A8 equivalent.) Power,

contacts, and output: 21mm dia., use cable of 9 to 12 mm dia. (plastic gland, watertight to JIS A15 equivalent.)

Weight:

Body: Approx. 2.5 kg

Mounting bracket: Approx. 0.4 kg

Dimensions: 144(W) x 144(H) x 135(D) mm

Standard Performance

Repeatability: 0.5% of input span (not including sensor)

Linearity: 0.5% of input span (not including sensor)

Operating Functions

Display: 3-1/2 digit digital display (data display)

Six digital alphanumerics (message or data display)

Display items: ORP value (mV)

mA output

Zero-shift value

Interactive prompts

Key entry request (for hold value)

Error display (if error occurs)

Fail display (if failure occurs)

Operation-mode actions:

Message area display content selection

Set / release output hold setting

Manual calibration (one-point)

Maintenance-mode actions:

Setting of alarms S1, S2 and S3

Setting of output ranges

Setting of hold parameters

Enable/disable hold

Hold last value / Hold preset value setting

Setting of preset value

Setting of wash parameters

Selection of auto/manual wash

Manual wash start/stop

Auto wash enable/disable

Wash cycle interval: settable 0.1 to 36 hours

Settling time: settable 0.1 to 10 min.

Wash cycle duration: settable 0.1 to 10 min.

Service-mode actions:

Zero point check

Settling (to 50%) time check On / Off

Settling (to 50%) time setting (0.1 to 10 min.)

Burnout (upscale/downscale/Off)

Mode auto revert On / Off

Converter mA output On / Off

Error reset

Items detected by self-diagnostics:

ORP measurement value abnormal

Zero point shift abnormal

Settling time abnormal

EEPROM abnormal

2. Ultrasonic Oscillator (Non-Explosionproof Type) PUS400G

Combination device:

Holder with ultrasonic cleaner (PH8HS, PH8HF)

Connection cable are provided with holders.

Cleaning method: Continuous ultrasonic emission (Frequency sweep method)

Oscillation frequency: Approx. 61 to 81 kHz

Output voltage: Approx. 70 V

Power supply: 100/110/115/200/220/240 V AC ± 10% 50/60Hz

When ordering, specify model and codes, product name and/or parts numbers. Items to specified shown as below.

Item	Name	Model	Remarks
1	ORP converter	OR400G	
2	Ultrasonic oscillator	PUS400G	For ultrasonic cleaning only
3	Solenoid valve	PH8MV	For jet or brush cleaning only
4	Cleaning pump/Tank	PH8PU1	For jet or brush cleaning only, enables cleaning with tap water from tank or water-supply side
5	Terminal box	OR8TBG	Only for installation or ORP converter at distance from ORP sensor
6	Accessories	OR8AX	For the set of startup instrument
7	Consumable		Specify for required parts

Note: For the ORP electrodes, see GS 12B07B02-E. For the holders or cleaning devices, see GS 12J5C2-E.

T02-1.EPS

MODEL AND SUFFIX CODES

1. 4-wire type ORP Converter OR400G

Model	Suffix Code	Option Code	Specifications
OR400G	4-wire ORP Converter
Power supply	-1	100/110 V AC, 50/60 Hz
	-2	200/220 V AC, 50/60 Hz
Language for warning, etc.	-J	Japanese
	-E	English
_____	-A	Always "-A"
Option	Mounting hardware	/U	Pipe and wall mounting hardware
		/PM	Panel mounting hardware
		/H3	Awning hood (carbon steel)
		/H4	Awning hood (stainless steel)
		/X1	Epoxy- coated (baked)
		/SCT	Stainless tag plate
		/AFTG	G1/2
Conduit Adapter	/ANSI	1/2NPT	
	/SPS	Teflon coated SUS steel screws	

T14.EPS

2. Ultrasonic Oscillator PUS400G

Model	Suffix Code	Option Code	Description
PUS400G	Ultrasonic oscillator
_____	-NN	Always -NN
Application	-NN	General purpose
Power Supply	-1	100V AC 50/60 Hz
	-2	110V AC 50/60 Hz
	-3	115V AC 50/60 Hz
	-4	200V AC 50/60 Hz
	-5	220V AC 50/60 Hz
	-6	240V AC 50/60 Hz
Language	-J	Japanese
	-E	English
Options	Mounting Bracket	/PS	Pipe mounting bracket (stainless steel)
		/W	Wall mounting bracket (stainless steel)
		/PA	Panel mounting bracket (stainless steel)
	Hood	/H	Awning hood
	Special Finish	/X1	Baked epoxy resin
	Tag Plate	/SCT	Stainless steel tag plate
	Conduit Adapter	/AFTG	G1/2
/ANSI		1/2 NPT	

T15.EPS

3. Solenoid Valve for Jet/Brush Cleaning PH8MV

Model	Suffix Code	Option Code	Description
PH8MV	Solenoid valve
Fluid	-A	Air
	-W	Water
Power Supply voltage	-100	100V AC
	-110	110V AC
	-200	200V AC
	-220	220V AC
Power Supply Frequency	-50	50Hz
	-60	60Hz
Style Code	*C	Style C

T16.EPS

4. Cleaning Pump/Tank Assembly PH8PU1

Model	Suffix Code	Option Code	Description
PH8PU1	Cleaning tank / pump assembly
Power Supply	-3	200V AC, 50/60 Hz
	-5	100V AC, 50/60 Hz
Style code	*B	Style B
Options		/PT	With Rc 1/2 adapter
Cleaning Water Inlet/Outlet		/NP	With 1/2 NPT adapter
Anchor volts		/AN	4 L-shape M12 x 160 (SS41) bolts
Conduit adapter		/APUG	G 1/2
		/ANSI	1/2NPT

T17.EPS

5. Terminal Box OR8TBG

Model	Suffix Code	Option Code	Specifications
OR8TBG	Terminal box
Dedicated cable length	-C□□	Specify cable length (m) in □□ maximum 20 m. Example: For 3 m cable /03
Style	*A	Style A
Option	Mounting hardware	/P	Pipe mounting hardware
		/W	Wall mounting hardware
	Conduit Adaptor	/ATBG	G1/2 female

T18.EPS

6. Accessories OR8AX

Model	Suffix Code	Option Code	Specifications
OR8AX	Accessories for ORP meter(*1)
Style	*A	Style A
Option (*2)		/STD	Sensor stand (with mounting bracket for 50A 2-inch pipe)
		/KCLL	KCl solution (one 250ml polyethylene bottle)
		/KCLP	KCl powder (three bags, 250ml solution each)
		/TMP	Thermometer (0 to 100 °C)

- * 1: Including the following:
Two 200ml polyethylene cups
One cleaning bottle
One pack of quinhydrone reagent powder (three bags, 250ml solution each)
One 250ml polyethylene bottle
- * 2: Either /KCLL or /KCLP is required for OR8EFG-□-□-TT2.

T19.EPS

7. Spare Parts

Part Name	Part Number	Remarks	
Junction	K9142TH	One for OR8ERG,OR8EFG	
Desiccant	K9020XR	One packed	
KCl solution (3.3mol/l)	K9084LP	Six 250ml polyethylene bottles	
KCl powder (for OR8EFG)	K9020XU	8 bags, each for preparation of 250ml	
KCl powder (for OR8ERG)	K9142UT	2 bags 1 bottle of 3.3mol/l KCl, 1 syringe	
Reagent for check	Quinhydrone	K9024EC	3 bags, each for preparation of 250ml
	Iron	K9024ED	3 bags, each for preparation of 250ml
Brush	K9143KM	for preparation of Holder	
Conduit Adapter	K9141TX	for additional of /AFTB	

T20.EPS

DIMENSIONS

ORP Converter

UNIT: mm

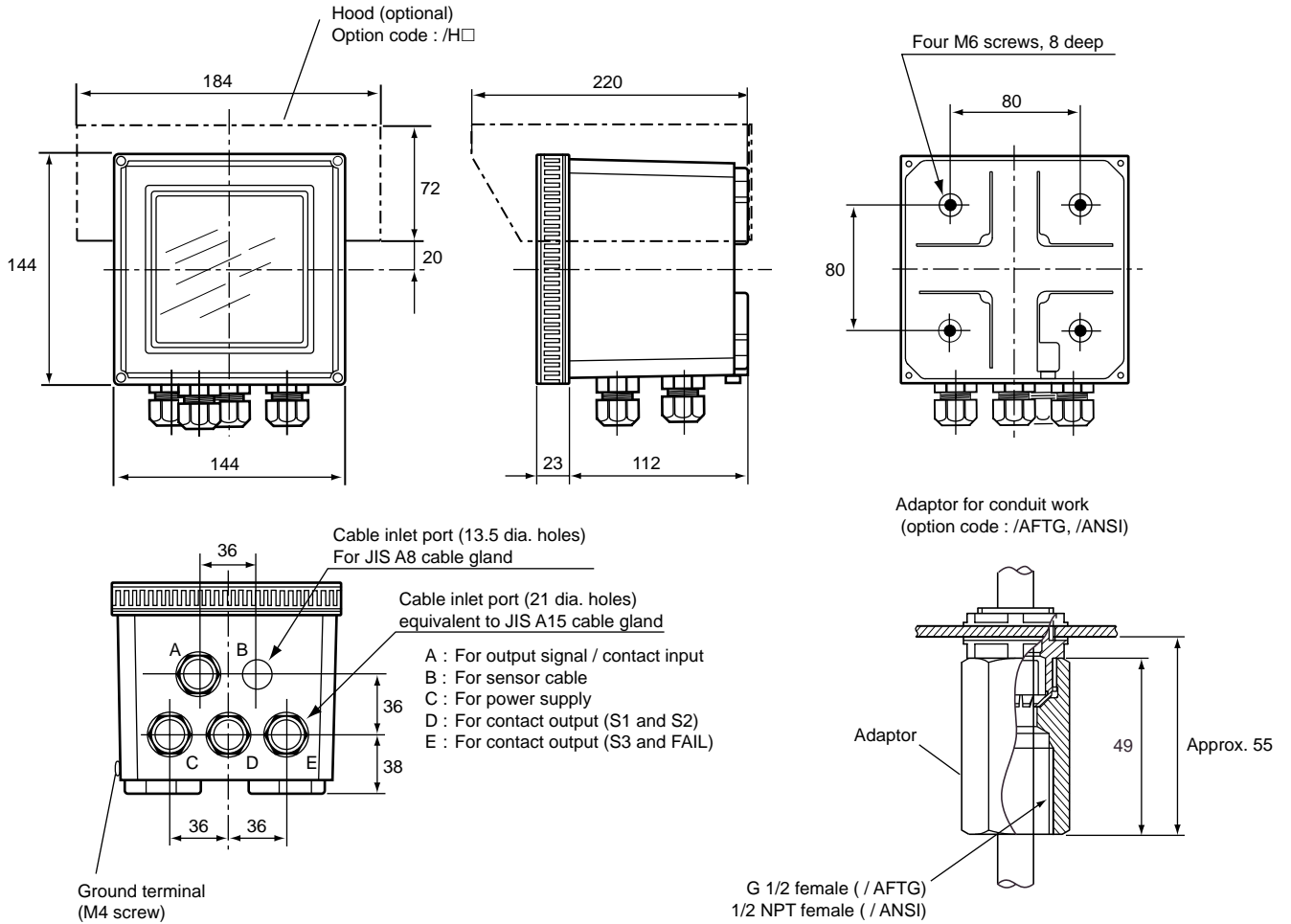

Pipe Mounting Bracket / Wall Mounting Bracket (option code : /U)

UNIT: mm

•Example of bracket used for pipe mounting

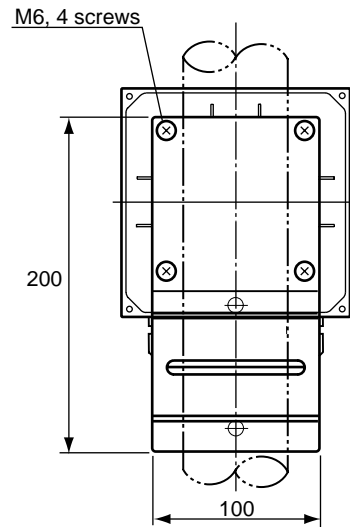
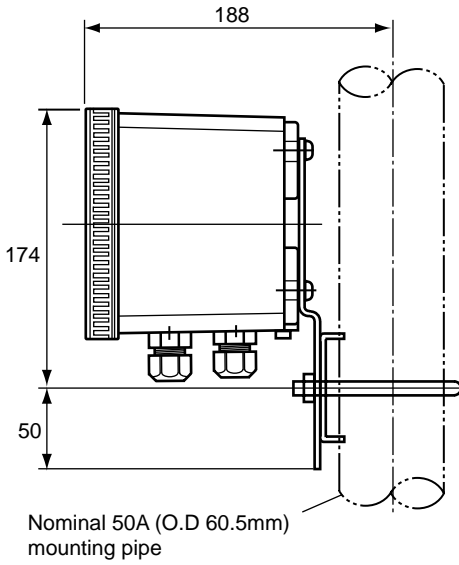

•Example of bracket used for wall mounting

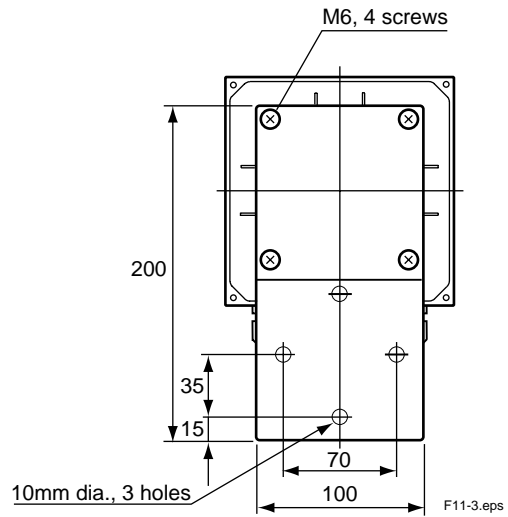
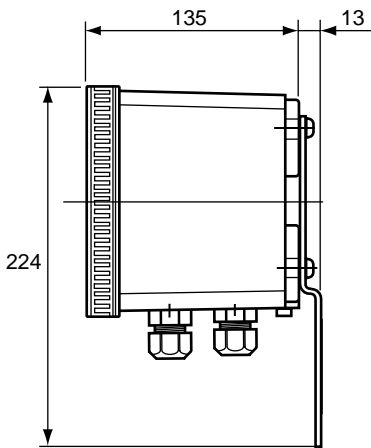

Panel Mounting Bracket (option code : / PM)

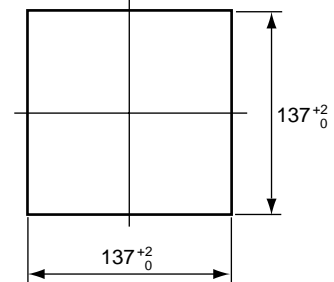
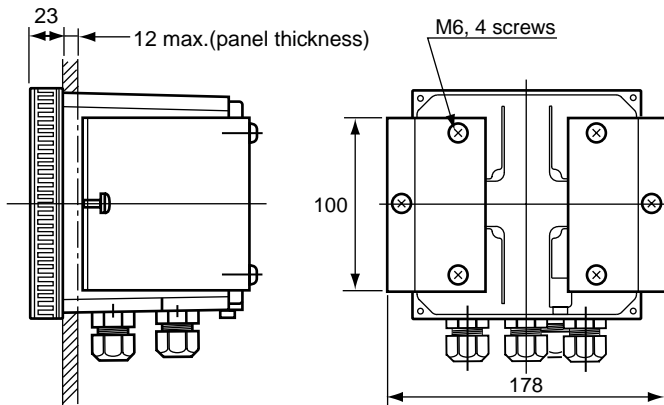

Panel cutout dimensions

F11-1.eps

Ultrasonic Oscillator (PUS400G)

UNIT: mm

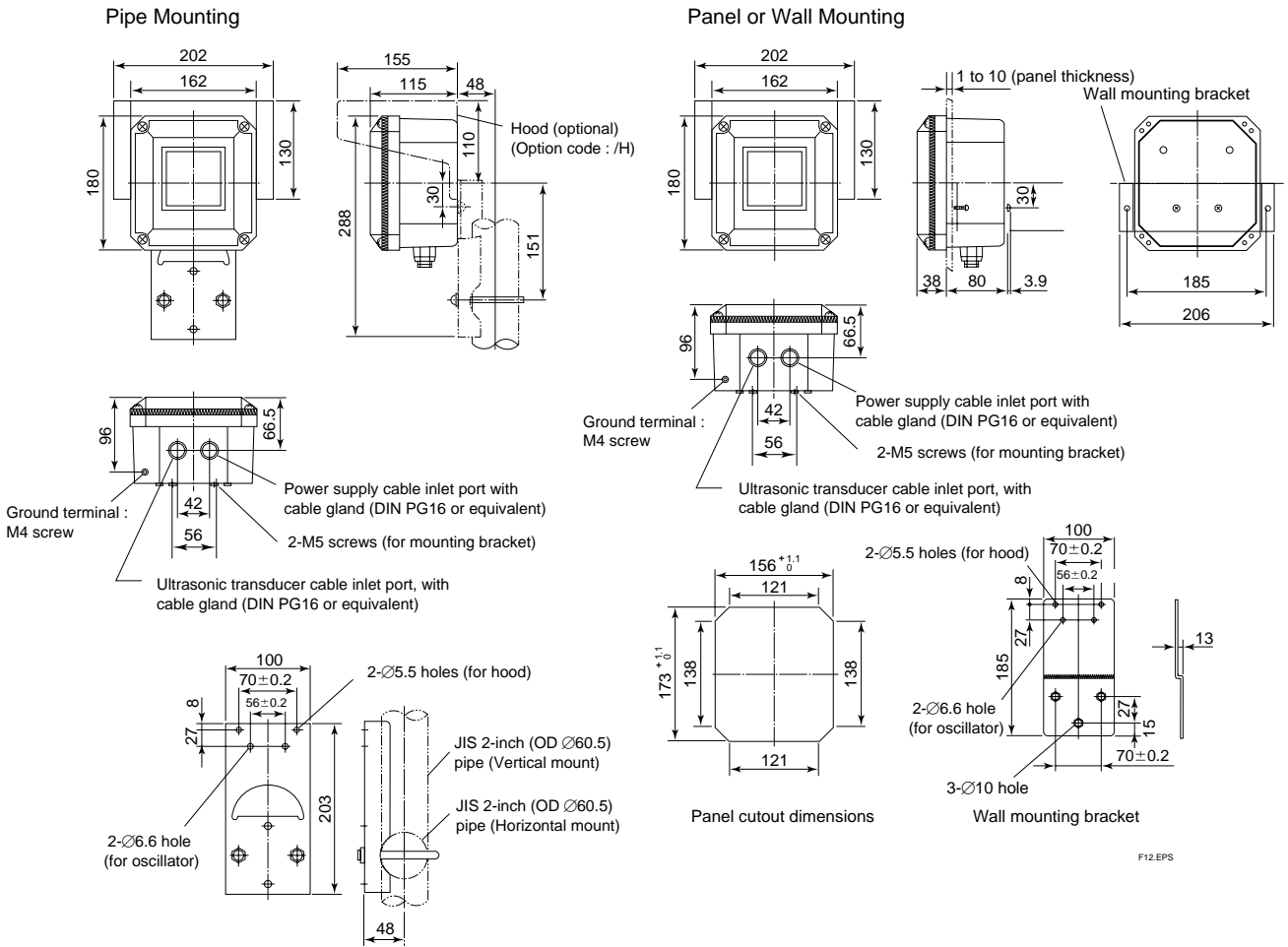

Solenoid Valve for Jet/Brush Cleaning PH8MV

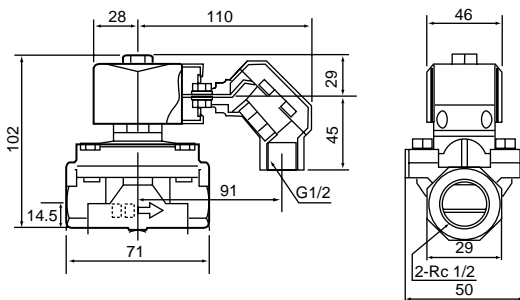

Cautions on Installation of Solenoid Valve for Jet / Brush Cleaning

- Do not allow a sample solution to flow backward into the solenoid valve or to be replaced with the driving fluid.
For this take relevant measures; e.g. install a check valve to prevent inverse pressure between the inlet and outlet of the solenoid valve, or install the solenoid valve higher than the holder, especially when using the air jet/brush cleaning system.
- Make sure to avoid the risk of corrosion of the solenoid body (bronze) and seal (nitrile rubber) by vapor or gaseous components generated from a sample solution, especially when using the air jet/brush cleaning system.

F15.EPS

Terminal Box (OR8TBG)

UNIT: mm

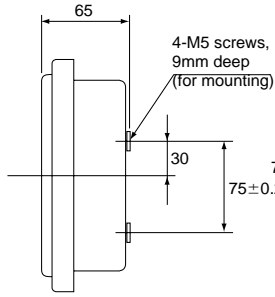
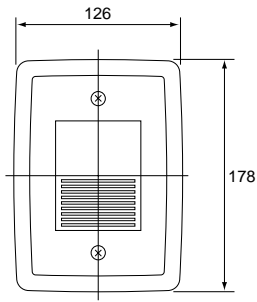

Pipe Mounting Bracket (with /P option)

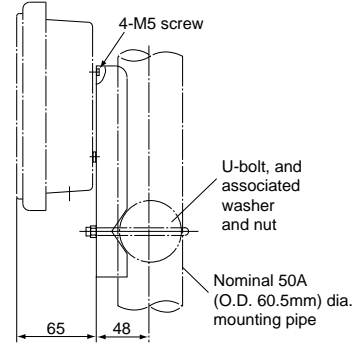
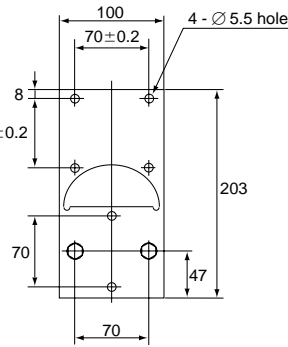

Extension cable covering
(Applicable cable gland : equivalent to JIS A15)

Sensor cable covering ; (punched out when wired)
(Applicable cable gland : equivalent to JIS A8)

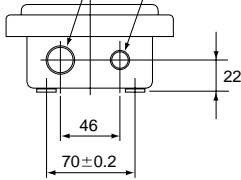

Wall Mounting Bracket (with /W option)

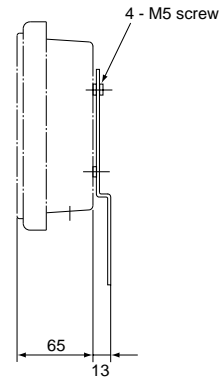
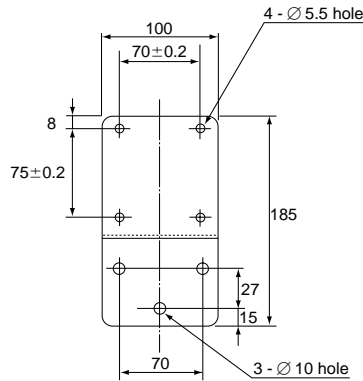

F08.EPS

Details of cable gland of ultrasonic oscillator and terminal box

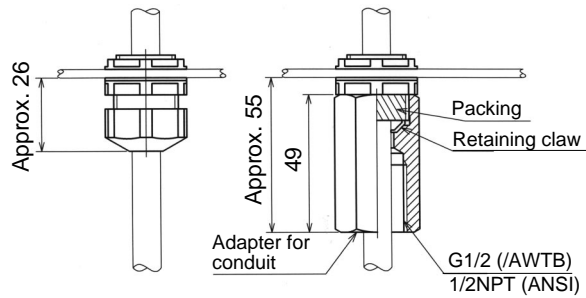

F13.EPS

Cleaning Pump/Tank Assembly PH8PU1

UNIT: mm

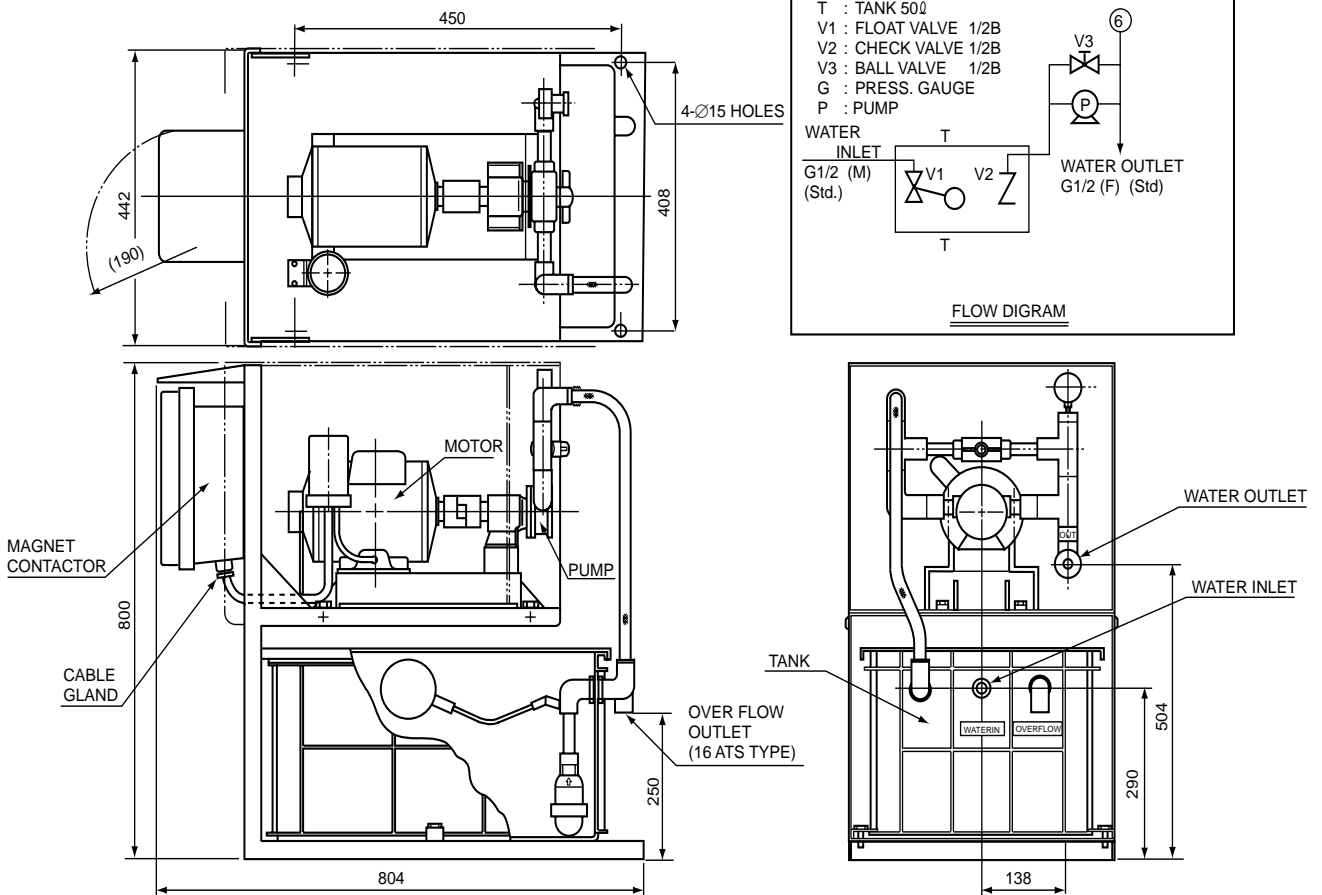

F14.eps

WIRING DIAGRAM

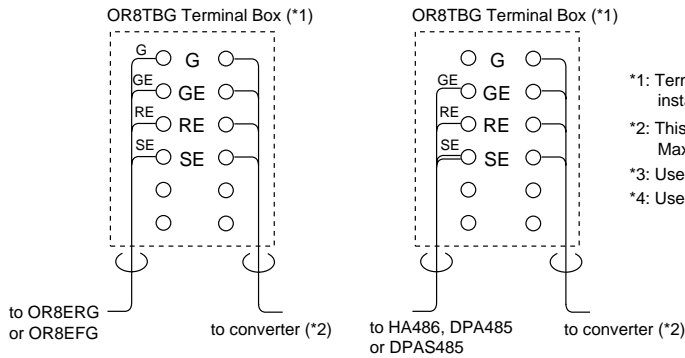
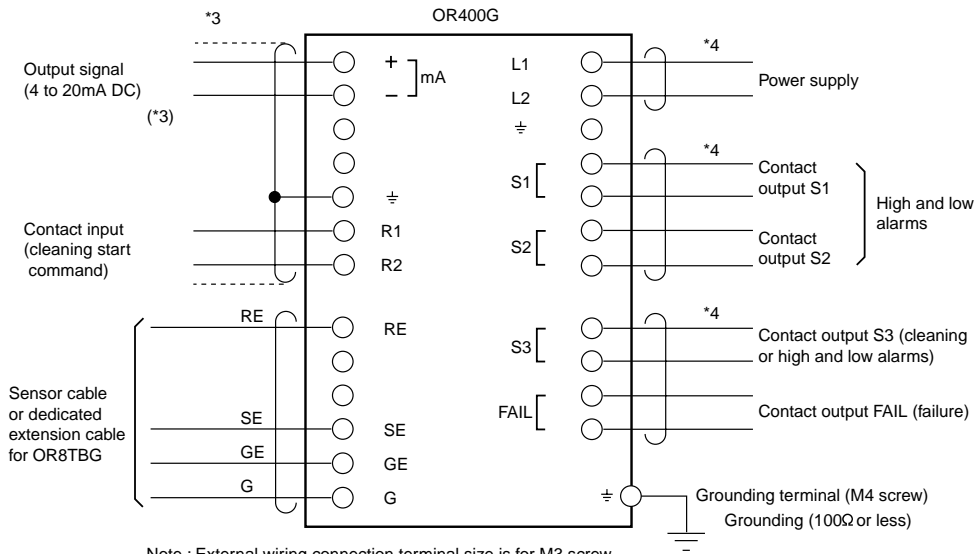

- *1: Terminal box is used only where converter is installed some distance from ORP sensor (ordinarily not needed).
- *2: This cable is specified in the option code for the OR8TBG. Maximum length is 20 m.
- *3: Use only shielded pair cable with an outside diameter of 9 to 12 mm.
- *4: Use only cable with an outside diameter of 9 to 12 mm.

F01.eps

< Wiring for non-explosionproof ultrasonic cleaning system >

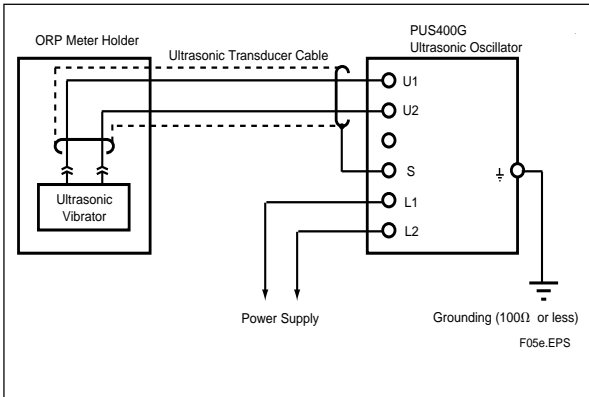

F02.eps

< Notes for Conduit Installation >

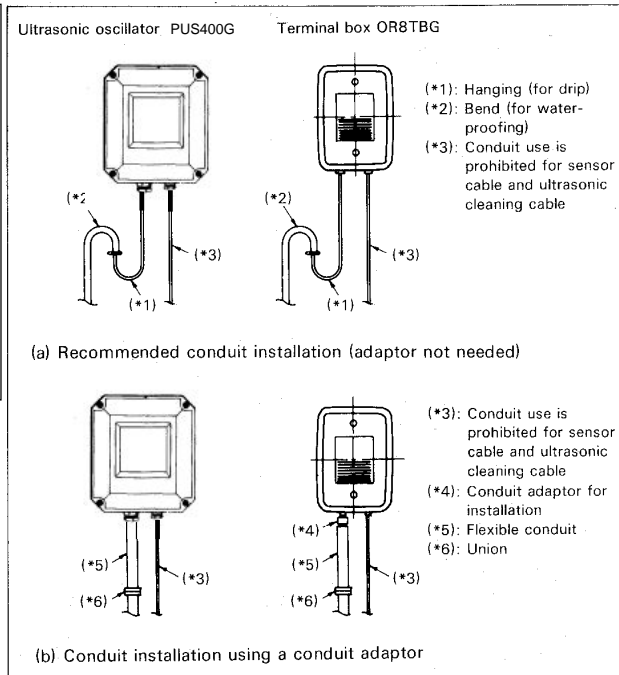

INQUIRY SHEET for 4-wire ORP CONVERTER OR400G

1 General Information

Company name; _____
 Contact Person; _____ Department; _____
 Plant name; _____
 Measurement location; _____
 Purpose of use; Indication, Recording, Alarm, Control
 Power supply; _____ V AC _____ Hz

2 Measurement Conditions

(1) Process temperature; _____ to _____ Normally _____ [°C]
 (2) Process pressure; _____ to _____ Normally _____ [kPa]
 (3) Flow rate; _____ to _____ Normally _____ [l/min]
 (4) Flow speed; _____ to _____ Normally _____ [m/s]
 (5) Slurry or contaminants; No, Yes _____
 (6) Name of process fluid; _____
 (7) Components of process fluid; _____
 (8) Others; _____

3 Installation Site

(1) Ambient temperature; _____
 (2) Location; Outdoors, Indoors _____
 (3) Others; _____

4 Requirements

(1) Measuring range; _____ to _____ mV
 (2) Converter output; 4 to 20 mA DC
 (3) System configuration selection; Electrode, Holder, ORP Converter, Cleaning system, Terminal box,
Accessories
 (4) Electrode cable length; 3 m, 5 m, 7 m, 10 m, 15 m, 20 m, ____m
 (5) Electrode operating pressure; 10 kPa or less, Greater than 10 kPa
 (6) Type of holder; Guide pipe, Submersion, Flow-through, Removable
 (7) Cleaning method; No cleaning, Ultrasonic cleaning, Jet cleaning, Brush cleaning
 (8) Sample temperature; _____ to _____ °C
 (9) Others; _____