

General Specifications

EJX115A Low Flow Transmitter



GS 01C25K01-01E

[Style: S1]

The low flow transmitter EJX115A is a differential pressure transmitter assembled with an integral orifice and excellent for very low flow measurement. It outputs a 4 to 20 mA DC signal corresponding to the measured flow. Its highly accurate and stable sensor can also measure the static pressure which can be shown on the integral indicator or remotely monitored via BRAIN or HART communications. Other key features include quick response, remote set-up using communications, diagnostics and optional status output for pressure high/low alarm. The multi-sensing technology provides the advanced diagnostic function to detect such abnormalities as an impulse line blockage or heat trace breakage. FOUNDATION Fieldbus protocol type is also available. All EJX series models in their standard configuration, with the exception of the Fieldbus type, are certified by TÜV as complying with SIL 2 for safety requirement.



STANDARD SPECIFICATIONS

Refer to GS 01C25T02-01E for Fieldbus communication type marked with “◇.”

SPAN AND RANGE LIMITS

Capsule	Differential Pressure Span	Water Equivalent Flow l/min	Air Equivalent Flow NI/min
L	1 to 10 kPa {100 to 1000 mmH ₂ O}	0.016 to 7.2	0.44 to 198
M	2 to 100 kPa {200 to 10000 mmH ₂ O}	0.022 to 23.0	0.63 to 635
H	20 to 210 kPa {2000 to 21000 mmH ₂ O}	0.07 to 33.0	2.0 to 910

T01E.EPS

PERFORMANCE SPECIFICATIONS

[Integral Orifice]

Accuracy ±5% of span

Refer to TI 01C20K00-01E for conditions.

[Differential Pressure Transmitter]

Zero-based calibrated span, linear output, wetted parts material code S and silicone oil, unless otherwise mentioned.

For Fieldbus communication type, use calibrated range instead of span in the following specifications.

Specification Conformance

EJX series ensures specification conformance to at least ±3σ.

Reference Accuracy of Calibrated Span

(includes terminal-based linearity, hysteresis, and repeatability)

Measurement span		H
Reference accuracy	X ≤ span	±0.04% of Span
	X > span	±(0.005+0.0049 URL/span)% of Span
X		70 kPa (280 inH ₂ O)
URL (upper range limit)		500 kPa (2000 inH ₂ O)

T02E.EPS

Measurement span		M
Reference accuracy	X ≤ span	±0.04% of Span
	X > span	±(0.005+0.0035 URL/span)% of Span
X		10 kPa (40 inH ₂ O)
URL (upper range limit)		100 kPa (400 inH ₂ O)

T03E.EPS

Measurement span		L
Reference accuracy	X ≤ span	±0.04% of Span
	X > span	±(0.015+0.005 URL/span)% of Span
X		2 kPa (8 inH ₂ O)
URL (upper range limit)		10 kPa (40 inH ₂ O)

T04E.EPS

Square Root Output Accuracy

The square root accuracy is a percent of flow span.

Output	Accuracy
50% or Greater	Same as reference accuracy
50% to Dropout point	$\frac{\text{Reference accuracy} \times 50}{\text{Square root output (\%)}}$

T05E.EPS

Ambient Temperature Effects per 28°C (50°F) Change

Capsule	Effect
H	±(0.04% Span+0.0125% URL)
M	±(0.04% Span+0.009% URL)
L	±(0.055% Span+0.09% URL)

Static Pressure Effects per 6.9 MPa (1000 psi) Change

Span Effects

L, M and H capsules
±0.075% of span

Effect on Zero

Capsule	Effect
H	±0.028% URL
M	±0.02% URL
L	±0.05% URL

Overpressure Effects

Overpressure condition: up to maximum working pressure

M and H capsules
±0.03% of URL

Stability (All normal operating condition, including overpressure effects)

M and H capsules
±0.1% of URL per 10 years

Power Supply Effects (Output signal code D and E)
±0.005 % per Volt (from 21.6 to 32 V DC, 350 Ω)

Vibration Effects

Amplifier housing code 1:

Less than 0.1% of URL when tested per the requirements of IEC60770-1 field or pipeline with high vibration level (10-60 Hz, 0.21 mm peak to peak displacement/60-2000 Hz 3 g)

Amplifier housing code 2:

Less than ±0.1% of URL when tested per the requirements of IEC60770-1 field with general application or pipeline with low vibration level (10-60 Hz 0.15mm peak to peak displacement /60-500 Hz 2g)

Mounting Position Effects

Rotation in diaphragm plane has no effect. Tilting up to 90 degree will cause zero shift up to 0.4 kPa (1.6 inH₂O) which can be corrected by the zero adjustment.

Response Time (Differential pressure) “◇”

L, M and H capsules : 90 msec
When amplifier damping is set to zero and including dead time of 45 msec (nominal)

Static Pressure Signal Range and Accuracy

(For monitoring via communication or on indicator. Includes terminal-based linearity, hysteresis, and repeatability)

Range

Upper Range Value and Lower Range Value of the static pressure can be set in the range between 0 and Maximum Working Pressure(MWP). The upper range value must be greater than the lower range value. Minimum setting span is 0.5 MPa(73 psi). Measuring either the pressure of high pressure side or low pressure side is user-selectable.

Accuracy

Absolute Pressure

1MPa or higher : ±0.2% of span
Less than 1 MPa: ±0.2%×(1 MPa/span) of span

Gauge Pressure Reference

Gauge pressure reference is 1013 hPa (1 atm)
Note : Gauge pressure variable is based on the above fixed reference and thus subject to be affected by the change of atmospheric pressure.

□ **FUNCTIONAL SPECIFICATIONS**

Output “◇”

Two wire 4 to 20 mA DC output with digital communications, linear or square root programmable. BRAIN or HART FSK protocol are superimposed on the 4 to 20 mA signal.

Output range: 3.6 mA to 21.6 mA
Output limits conforming to NAMUR NE43 can be pre-set by option code C2 or C3.

Failure Alarm (Output signal code D and E)

Analog output status at CPU failure and hardware error;

Up-scale: 110%, 21.6 mA DC or more (standard)
Down-scale: -5%, 3.2 mA DC or less

Analog output status at process abnormality (Option code /DG6);

The result of process abnormality detected by the advanced diagnostic function can be reflected to an analog alert status. The following three setting modes are available.

		Mode		
		Burnout	Fall back	Off
Standard		110 %, 21.6mA or more	Holds to a specified value within the output range from 3.6mA to 21.6mA	Not Available (normal output)
Option Code	/C1	-2.5%, 3.6mA or less		
	/C2	-1.25%, 3.8mA or less		
	/C3	103.1%, 20.5mA or more		

T13E.EPS

Damping Time Constant (1st order)

Amplifier damping time constant is adjustable from 0.00 to 100.00 sec by software and added to response time.

Note: For BRAIN protocol type, when amplifier software damping is set to less than 0.5 sec, communication may occasionally be unavailable during the operation, especially while output changes dynamically. The default setting of damping ensures stable communication.

Update Period “◇”

Differential pressure: 45 msec
Static pressure: 360 msec

Zero Adjustment Limits

Zero can be fully elevated or suppressed, within the lower and upper range limits of the capsule.

External Zero Adjustment

External zero is continuously adjustable with 0.01% incremental resolution of span. Re-range can be done locally using the digital indicator with range-setting switch.

Integral Indicator (LCD display, optional) “◇”

5-digit numerical display, 6-digit unit display and bar graph.

The indicator is configurable to display one or up to four of the following variables periodically.;
Measured differential pressure, differential pressure in %, scaled differential pressure, measured static pressure. See also “Factory Setting.”

Burst Pressure Limits

(Differential pressure transmitter part)

69 MPa (10,000 psi)

Self Diagnostics

CPU failure, hardware failure, configuration error, and over-range error for differential pressure, static pressure and capsule temperature.

User-configurable process high/low alarm for differential pressure and static pressure is also available, and its status can be output when optional status output is specified.

Advanced Diagnostics (optional) “◇”

Applicable for Output signal code E and F.

- Impulse line blockage detection
The impulse line condition can be calculated and detected by extracting the fluctuation component from the differential pressure and static pressure signals. The EJX115A detects the impulse line abnormality particularly which side of impulse line is plugged.
- Heat trace monitoring
The change of the flange temperature calculated by using the two temperature sensors built in the EJX enables to detect the heat trace breakage or the abnormal temperature due to the failure.

Signal Characterizer (Output signal code D and E)

User-configurable 10-segment signal characterizer for 4 to 20 mA output.

Status Output (optional, output signal code D and E)

One transistor contact output (sink type) to output the status of user configurable high/low alarm for differential pressure/static pressure.

Contact rating : 10.5 to 30 V DC, 120 mA DC max. Refer to ‘Terminal Configuration’ and ‘Wiring Example for Analog Output and Status Output.’

SIL Certification

EJX series transmitters except Fieldbus communication type are certified by TÜV in compliance with the following standards;

IEC 61508: 2000; Part1 to Part 7

Functional Safety of Electrical/electronic/programmable electronic related systems; SIL 2 capability for single transmitter use, SIL 3 capability for dual transmitter use.

□ NORMAL OPERATING CONDITION

(Optional features or approval codes may affect limits.)

Ambient Temperature Limits

- 40 to 85°C (-40 to 185°F)
- 30 to 80°C (-22 to 176°F) with LCD display

Process Temperature Limits

- 40 to 120°C (-40 to 248°F)

Ambient Humidity Limits

- 0 to 100% RH

Working Pressure Limits (Silicone oil)

Maximum Pressure Limits

All capsules 16 MPa (2300 psi)

Minimum Pressure Limit

See graph below

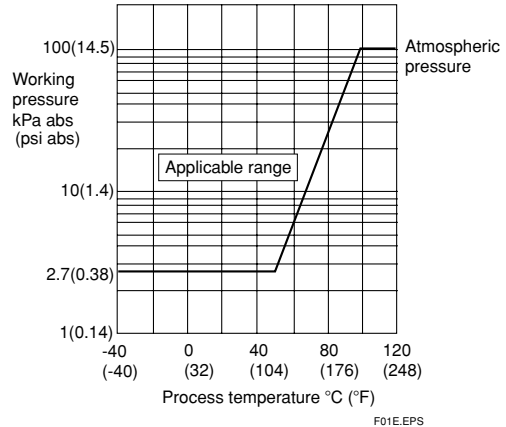

Figure 1. Working Pressure and Process Temperature

Supply & Load Requirements

(Output signal code D and E. Optional features or approval codes may affect electrical requirements.)

With 24 V DC supply, up to a 550 Ω load can be used. See graph below.

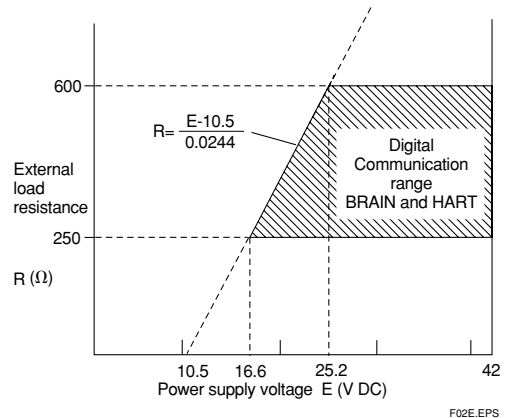

Figure 2. Relationship Between Power Supply Voltage and External Load Resistance

Supply Voltage “◇”

- 10.5 to 42 V DC for general use and flameproof type.
- 10.5 to 32 V DC for lightning protector (option code / A.)
- 10.5 to 30 V DC for intrinsically safe, type n, or non-incendive.

Minimum voltage limited at 16.6 V DC for digital communications, BRAIN and HART

Load (Output signal code D and E)

- 0 to 1290 Ω for operation
- 250 to 600 Ω for digital communication

Communication Requirements “◇”

(Approval codes may affect electrical requirements.)

BRAIN

Communication Distance

Up to 2 km (1.25 miles) when using CEV polyethylene-insulated PVC-sheathed cables. Communication distance varies depending on type of cable used.

Load Capacitance

0.22 μF or less

Load Inductance

3.3 mH or less

Input Impedance of communicating device

10 kΩ or more at 2.4 kHz.

EMC Conformity Standards  , 

EN61326-1 Class A, Table2 (For use in industrial locations)
EN61326-2-3

European Pressure Equipment Directive 97/23/EC

Sound Engineering Practice (for all capsules)

□ PHYSICAL SPECIFICATIONS

Wetted Parts Materials

Diaphragm, Cover Flange, Process Connector, Capsule Gasket, Vent/Drain Plug, Manifold, Orifice, Spacer, and Orifice gasket
Refer to “MODEL AND SUFFIX CODES.”

Process Connector Gasket

PTFE Teflon

Fluorinated rubber for option code N2 and N3

Non-wetted Parts Materials

Bolting

ASTM-B7 carbon steel or 316L SST stainless steel

Housing

Low copper cast aluminum alloy with polyurethane, mint-green paint (Munsell 5.6BG 3.3/2.9 or its equivalent), or ASTM CF-8M Stainless Steel

Degrees of Protection

IP67, NEMA4X, JIS C0920

Cover O-rings

Buna-N

Name plate and tag

304 SST, 316 SST (optional)

Fill Fluid

Silicone, fluorinated oil (optional)

Weight

[Installation code 7, 8 and 9]

4.5 kg (9.9 lb) without integral indicator and mounting bracket.

Add 1.5 kg (3.3 lb) for Amplifier housing code 2.

Connections

Refer to “MODEL AND SUFFIX CODES.”

Process connection of cover flange: IEC61518

< Related Instruments >

Power Distributor: Refer to GS 01B04T01-02E or GS 01B04T02-02E

BRAIN TERMINAL: Refer to GS 01C00A11-00E

< Reference >

1. Teflon; Trademark of E.I. DuPont de Nemours & Co.
2. Hastelloy; Trademark of Haynes International Inc.
3. HART; Trademark of the HART Communication Foundation.
4. FOUNDATION Fieldbus; Trademark of Fieldbus Foundation.

Other company names and product names used in this material are registered trademarks or trademarks of their respective owners.

< Measurement Range (Approximate Value) >

	Orifice Bore (mm)	L Capsule	M Capsule	H Capsule
Water Equivalent Maximum Flow Range l/min	0.508	0.016 to 0.049	0.022 to 0.157	0.07 to 0.225
	0.864	0.046 to 0.145	0.066 to 0.46	0.21 to 0.67
	1.511	0.134 to 0.42	0.19 to 1.35	0.60 to 1.93
	2.527	0.36 to 1.15	0.52 to 3.6	1.65 to 5.2
	4.039	0.92 to 2.9	1.3 to 9.2	4.1 to 13.0
Air Equivalent Maximum Flow Range NI/min	6.350	2.3 to 7.2	3.3 to 23	10 to 33
	0.508	0.44 to 1.40	0.63 to 4.4	1.98 to 6.4
	0.864	1.30 to 4.10	1.85 to 12.9	5.8 to 18.5
	1.511	3.7 to 11.7	5.3 to 37	16.7 to 54
	2.527	10.3 to 32	14.6 to 105	47 to 150
4.039	25 to 79	36 to 255	113 to 370	
	6.350	63 to 198	89 to 630	280 to 910

T06E.EPS

MODEL AND SUFFIX CODES

Model	Suffix Codes	Description
EJX115A	Low flow transmitter
Output signal	-D	4 to 20 mA DC with digital communication (BRAIN protocol)
	-E	4 to 20 mA DC with digital communication (HART protocol)
	-F	Digital communication (FOUNDATION Fieldbus protocol, refer to GS 01C25T02-01E)
Measurement span (capsule)	L	1 to 10 kPa (4 to 40 inH ₂ O)
	M	2 to 100 kPa (8 to 400 inH ₂ O)
	H	20 to 210 kPa (80 to 840 inH ₂ O)
Wetted parts material *2	S	Cover flange and process connector: ASTM CF-8M # Capsule: Hastelloy C-276 (Diaphragm) # 316L SST (Others) # Capsule gasket: Teflon-coated 316L SST Drain/Vent plug: 316 SST # Orifice: 316 SST # Manifold: F316 SST # Spacer: 316 SST # Orifice gasket: PTFE
Process connections	2	Rc1/2 female
	4	1/2 NPT female
☆ Bolts and nuts material	J	For Cover flange SNB7 For Process connector SNB7 For Manifold 316L SST
	G	316L SST 316L SST 316L SST
Installation	-2	Vertical impulse piping type, right side high pressure, manifold upside
	-3	Vertical impulse piping type, right side high pressure, manifold downside
	-6	Vertical impulse piping type, left side high pressure, manifold upside
	-7	Vertical piping, left side high pressure, and manifold downside
	-8	Horizontal piping and right side high pressure
	-9	Horizontal piping and left side high pressure
☆ Amplifier housing	1	Cast aluminum alloy
	2	ASTM CF-8M stainless steel*3
Electrical connection	0	G1/2 female, one electrical connection without blind plugs
	☆ 2	1/2 NPT female, two electrical connections without blind plugs
	4	M20 female, two electrical connections without blind plugs
	5	G1/2 female, two electrical connections and a blind plug*4
	7	1/2 NPT female, two electrical connections and a blind plug*4
	9	M20 female, two electrical connections and a blind plug*4
	A	G1/2 female, two electrical connections and a SUS316 blind plug
	C	1/2 NPT female, two electrical connections and a SUS316 blind plug
	D	M20 female, two electrical connections and a SUS316 blind plug
Integral indicator	D	Digital indicator
	E	Digital indicator with the range setting switch*1
	☆ N	None
Mounting bracket	B	304 SST 2-inch pipe mounting, flat type (for horizontal piping)
	D	304 SST 2-inch pipe mounting, L type (for vertical piping)
	J	316 SST 2-inch pipe mounting, flat type (for horizontal piping)
	K	316 SST 2-inch pipe mounting, L type (for vertical piping)
	☆ N	None
—	-N ...	Always -N
—	00 ...	Always 00
—	N ...	Always N
—	N ..	Always N
—	0 .	Always 0
Optional Codes		/ <input type="checkbox"/> Optional specification

T07E.EPS

The “☆” marks indicate the most typical selection for each specification.

*1: Not applicable for output signal code **F**.

*2: ⚠ Users must consider the characteristics of selected wetted parts material and the influence of process fluids. The use of inappropriate materials can result in the leakage of corrosive process fluids and cause injury to personnel and/or damage to plant facilities. It is also possible that the diaphragm itself can be damaged and that material from the broken diaphragm and the fill fluid can contaminate the user's process fluids. Be very careful with highly corrosive process fluids such as hydrochloric acid, sulfuric acid, hydrogen sulfide, sodium hypochlorite, and high-temperature steam (150°C [302°F] or above). Contact Yokogawa for detailed information of the wetted parts material.

*3: Not applicable for electrical connection code **0**, **5**, **7** and **9**.

*4: Material of a blind plug is aluminum alloy or 304 SST.

*5: Cast version of 316 SST. Equivalent to SCS14A.

*6: Hastelloy C-276 or ASTM N10276.

The #marks indicate the construction materials conform to NACE material recommendations per MR01-75. For the use of 316 SST material, there may be certain limitations for pressure and temperature. Please refer to NACE standards for details.

OPTIONAL SPECIFICATIONS (For Explosion Protected type) “◇”

Item	Description	Code
Factory Mutual (FM)	FM Explosionproof Approval *1 Applicable Standard: FM3600, FM3615, FM3810, ANSI/NEMA 250 Explosionproof for Class I, Division 1, Groups B, C and D, Dust-ignitionproof for Class II/III, Division 1, Groups E, F and G, in Hazardous locations, indoors and outdoors (NEMA 4X) Temperature class: T6, Amb. Temp.: -40 to 60°C (-40 to 140°F)	FF1
	FM Intrinsically safe Approval *1*2 Applicable Standard: FM3600, FM3610, FM3611, FM3810 Intrinsically Safe for Class I, Division 1, Groups A, B, C & D, Class II, Division 1, Groups E, F & G and Class III, Division 1, Class I, Zone 0, in Hazardous Locations, AEx ia IIC Nonincendive for Class I, Division 2, Groups A, B, C & D, Class II, Division. 2, Groups F & G, and Class III, Division 1, Class I, Zone 2, Group IIC, in Hazardous Locations Enclosure: "NEMA 4X", Temp. Class: T4, Amb. Temp.: -60 to 60°C (-75 to 140°F) Intrinsically Safe Apparatus Parameters [Groups A, B, C, D, E, F and G] Vmax=30 V, Imax=200 mA, Pmax=1 W, Ci=6 nF, Li=0 μH [Groups C, D, E, F and G] Vmax=30 V, Imax=225 mA, Pmax=1 W, Ci=6 nF, Li=0 μH	FS1
	Combined FF1 and FS1 *1*2	FU1
CENELEC ATEX	CENELEC ATEX (KEMA) Flameproof Approval *1 Applicable Standard: EN 60079-0, EN 60079-1, EN 61241-0, EN 61241-1 Certificate: KEMA 07ATEX0109 II 2G, 2D Exd IIC T4, T5, T6 Ex tD A21 IP6X T85, T100, T120 Degree of protection : IP66 and IP67 Amb. Temp. (Tamb) for gas-proof : T4 ; -50 to 75°C (-58 to 167°F), T5; -50 to 80°C (-58 to 176°F), T6; -50 to 75°C (-58 to 167°F) Max. process Temp.(Tp): T4; 120°C (248°F), T5; 100°C (212°F), T6; 85°C (185°F) Max. surface Temp. for dust-proof : T85°C (Tamb: -40 to 40°C, Tp:85°C), T100°C (Tamb: -40 to 60°C, Tp:100°C), T120°C (Tamb: -40 to 80°C, Tp:120°C)	KF21
	CENELEC ATEX (KEMA) Intrinsically safe Approval *1*2 Applicable Standard: EN 50014, EN 50020, EN 50284, EN 50281-1-1 Certificate: KEMA 03ATEX1544X II 1G, 1D EEx ia IIC T4 Degree of protection : IP66 and IP67 Amb. Temp.(Tamb) for gas-proof: -50 to 60°C (-58 to 140°F) Maximum Process Temp.(Tp) for gas-proof :120°C Electrical data : Ui=30 V, li=200 mA, Pi=0.9 W, Ci=10 nF, Li=0 mH Max. surface Temp. for dust-proof : T85°C (Tamb: -40 to 60°C, Tp:80°C), T100°C (Tamb: -40 to 60°C, Tp:100°C), T120°C (Tamb: -40 to 60°C, Tp:120°C)	KS2
	Combined KF21, KS2 and Type n *1*2 Type n Applicable standard: EN60079-15 Referential standard: IEC60079-0, IEC60079-11 II 3G Ex nL IIC T4, Amb. Temp.: -50 to 60°C (-50 to 140°F) Ui=30 V DC, Ci=10 nF, Li=0 mH	KU21

T08E.EPS

*1: Applicable for Electrical connection code **2, 4, 7, 9, C** and **D**.

*2: Not applicable for option code **/AL**.

Item	Description	Code
Canadian Standards Association (CSA)	<p>CSA Explosionproof Approval *1 Certificate: 2014354 Applicable Standard: C22.2 No.0, C22.2 No.0.4, C22.2 No.0.5, C22.2 No.25, C22.2 No.30, C22.2 No.94, C22.2 No.60079-0, C22.2 No.60079-1, C22.2 No.61010-1-01 Explosion-proof for Class I, Groups B, C and D. Dustignition-proof for Class II/III, Groups E, F and G. When installed in Division 2, "SEAL NOT REQUIRED" Enclosure: TYPE 4X, Temp. Code: T6...T4 Ex d IIC T6...T4 Enclosure: IP66 and IP67 Max.Process Temp.: T4;120°C(248°F), T5;100°C(212 °F), T6; 85°C(185°F) Amb.Temp.: -50 to 75°C(-58 to 167°F) for T4, -50 to 80°C(-58 to 176°F) for T5, -50 to 75°C(-58 to 167°F) for T6</p> <p>Process Sealing Certification Dual Seal Certified by CSA to the requirement of ANSI/ISA 12.27.01 No additional sealing required Primary seal failure annunciation: at the zero adjustment screw</p>	CF1
	<p>CSA Intrinsically safe Approval *1*2 Certificate: 1606623 [For CSA C22.2] Applicable Standard: C22.2 No.0, C22.2 No.0.4, C22.2 No.25, C22.2 No.94, C22.2 No.154, C22.2 No.213, C22.2 No.1010.1 Intrinsically Safe for Class I, Division 1, Groups A, B, C & D, Class II, Division 1, Groups E, F & G, Class III, Division 1, Nonincendive for Class I, Division 2, Groups A, B, C & D, Class II, Division 2, Groups E, F & G, Class III, Division 1 Enclosure: Type 4X, Temp. Code: T4 Amb. Temp.: -50 to 60°C(-58 to 140°F) Electrical Parameters: [Intrinsically Safe] Vmax=30V, Imax=200mA, Pmax=0.9W, Ci=10nF, Li=0 [Nonincendive] Vmax=30V, Ci=10nF, Li=0</p> <p>[For CSA E60079] Applicable Standard: CAN/CSA E60079-0, CAN/CSA E60079-11, CAN/CSA E60079-15, IEC 60529:2001-02 Ex ia IIC T4, Ex nL IIC T4 Enclosure: IP66 and IP67 Amb. Temp.: -50 to 60°C(-58 to 140°F), Max. Process Temp.: 120°C(248°F) Electrical Parameters: [Ex ia] Ui=30V, li=200mA, Pi=0.9W, Ci=10nF, Li=0 [Ex nL] Ui=30V, Ci=10nF, Li=0</p> <p>Process Sealing Certification Dual Seal Certified by CSA to the requirement of ANSI/ISA 12.27.01 No additional sealing required Primary seal failure annunciation: at the zero adjustment screw</p>	CS1
	Combined CF1 and CS1 *1*2	CU1
IECEX Scheme *3	<p>IECEX Flameproof Approval *1 Applicable Standard: IEC 60079-0:2004, IEC60079-1:2003 Certificate: IECEX CSA 07.0008 Flameproof for Zone 1, Ex d IIC T6...T4 Enclosure: IP66 and IP67 Max.Process Temp.: T4;120°C(248°F), T5;100°C(212°F), T6; 85°C(185°F) Amb.Temp.: -50 to 75°C(-58 to 167°F) for T4, -50 to 80°C(-58 to 176°F) for T5, -50 to 75°C(-58 to 167°F) for T6</p>	SF2
	<p>IECEX Intrinsically safe, type n and Flameproof Approval *1*2 Intrinsically safe and type n Applicable Standard: IEC 60079-0:2000, IEC 60079-11:1999, IEC 60079-15:2001 Certificate: IECEX CSA 05.0005 Ex ia IIC T4, Ex nL IIC T4 Enclosure: IP66 and IP67 Amb. Temp.: -50 to 60°C(-58 to 140°F), Max. Process Temp.: 120°C(248°F) Electrical Parameters: [Ex ia] Ui=30V, li=200mA, Pi=0.9W, Ci=10nF, Li=0 [Ex nL] Ui=30V, Ci=10nF, Li=0</p> <p>Flameproof Applicable Standard: IEC 60079-0:2004, IEC60079-1:2003 Certificate: IECEX CSA 07.0008 Flameproof for Zone 1, Ex d IIC T6...T4 Enclosure: IP66 and IP67 Max.Process Temp.: T4;120°C(248°F), T5;100°C(212°F), T6; 85°C(185°F) Amb.Temp.: -50 to 75°C(-58 to 167°F) for T4, -50 to 80°C(-58 to 176°F) for T5, -50 to 75°C(-58 to 167°F) for T6</p>	SU2
Combination of approval	Combination of KU21, FU1 and CU1 *1*2	V1U

*1: Applicable for Electrical connection code **2, 4, 7, 9, C** and **D**.
 *2: Not applicable for option code **/AL**.
 *3: Applicable only for Australia, New Zealand, Singapore and India.

T09E.EPS

OPTIONAL SPECIFICATIONS

Item		Description	Code	
Painting	Color change	Amplifier cover only*7	P□	
		Amplifier cover and terminal cover, Munsell 7.5 R4/14	PR	
	Coating change	Anti-corrosion coating*17	X2	
316 SST exterior parts		316 SST name plate, tag plate and zero-adjustment screw*8	HC	
Lightning protector		Transmitter power supply voltage: 10.5 to 32 V DC (10.5 to 30 V DC for intrinsically safe type.) Allowable current: Max. 6000 A (1×40 μs), Repeating 1000 A (1×40 μs) 100 times Applicable Standards: IEC 61000-4-4, IEC 61000-4-5	A	
Status output*2		Transistor output (sink type) Contact rating : 10.5 to 30 V DC, 120 mA DC(max) Low level : 0 to 2 V DC	AL	
Oil-prohibited use		Degrease cleansing treatment	K1	
		Degrease cleansing treatment and fluorinated oilfilled capsule. Operating temperature -20 to 80°C(-4 to 176°F)	K2	
Oil-prohibited use with dehydrating treatment		Degrease cleansing and dehydrating treatment	K5	
		Degrease cleansing and dehydrating treatment with fluorinated oilfilled capsule. Operating temperature -20 to 80°C(-4 to 176°F)	K6	
Capsule fill fluid		Fluorinated oil filled in capsule Operating temperature -20 to 80°C(-4 to 176°F)	K3	
Calibration units*3		P calibration (psi unit)	(See Table for Span and Range Limits.)	
		bar calibration (bar unit)		
		M calibration (kgf/cm ² unit)		
Gold-plated diaphragm		Surface of isolating diaphragms are gold plated, effective for hydrogen permeation. Overpressure effects for M and H capsules: ±0.06% of URL	A1	
Long vent*4		Total length: 119 mm (standard: 34 mm); Total length when combining with option code K1, K2, K5, and K6: 130 mm. Material: 316 SST	U1	
Output limits and failure operation*5		Failure alarm down-scale : Output status at CPU failure and hardware error is -5%, 3.2mA DC or less.	C1	
		NAMUR NE43 Compliant Output signal limits : 3.8 mA to 20.5 mA	Failure alarm down-scale : Output status at CPU failure and hardware error is -5%, 3.2 mA DC or less.	C2
			Failure alarm up-scale : Output status at CPU failure and hardware error is 110%, 21.6 mA or more.	C3
Wired tag plate		304 SST tag plate wired onto transmitter (316 SST when /HC is specified)	N4	
Data configuration at factory*6		Data configuration for HART communication type	Software damping, Descriptor, Message	
		Data configuration for BRAIN communication type	Software damping	
Advanced diagnostics*12		Multi-sensing process monitoring • Impulse line blockage detection*13 • Heat trace monitoring	DG6	
Material certificate*11		Cover flange, Process connector, Manifold, Orifice, and Spacer	M12	
Pressure test/ Leak test certificate*10		Test Pressure: 16 MPa(2300 psi)	Nitrogen(N ₂) Gas*9 Retention time: one minute	

T10E.EPS

- *1: Not applicable with color change option.
- *2: Check terminals cannot be used when this option code is specified. Not applicable for output signal code F.
- *3: The unit of MWP (Max. working pressure) on the name plate of a housing is the same unit as specified by option codes **D1**, **D3**, and **D4**.
- *4: Applicable for vertical impulse piping type (Installation code **2**, **3**, **6**, or **7**).
- *5: Applicable for output signal codes **D** and **E**. The hardware error indicates faulty amplifier or capsule.
- *6: Also see 'Ordering Information'.
- *7: Not applicable for amplifier housing code **2**.
- *8: 316 or 316L SST. The specification is included in amplifier code **2**.
- *9: Pure nitrogen gas is used for oil-prohibited use (option codes **K1**, **K2**, **K5**, and **K6**).
- *10: The unit on the certificate is always Pa unit regardless of selection of option code **D1**, **D3** or **D4**.
- *11: Material traceability certification, per EN 10204 3.1B.
- *12: Applicable only for output signal code **-E**.
- *13: The change of pressure fluctuation is monitored and then detects the impulse line blockage. See TI 01C25A31-01E for detailed technical information required for using this function.

DIMENSIONS

Unit: mm(approx. inch)

● Vertical Impulse Piping Type

Process connector upside (Installation code 6)

Process connector downside (Installation code 7)

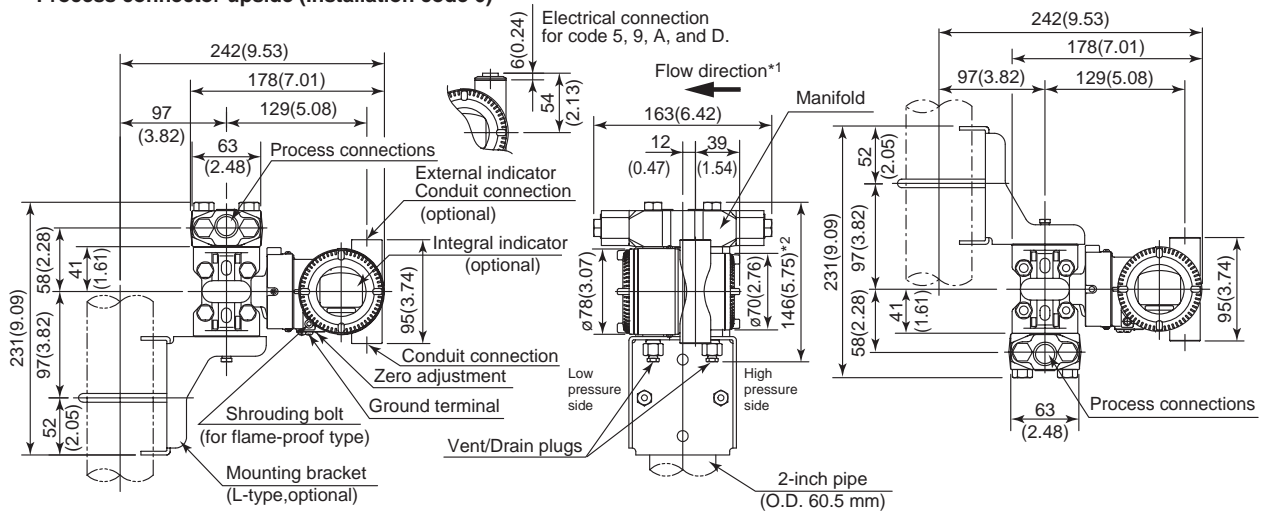

● Horizontal Impulse Piping Type (Installation code 9)

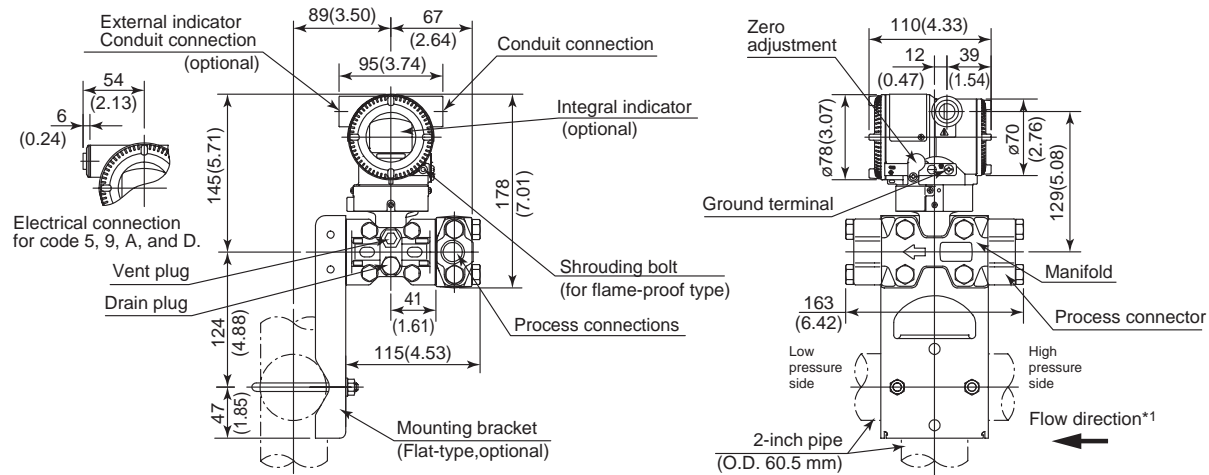

*1: When Installation code 2, 3, or 8 is selected, the flow direction on above figure is reversed. (i.e. the arrow faces to the left [←])

*2: When Option code K1, K2, K5, or K6 is selected, add 15 mm(0.59 inch) to the value in the figure.

F03E.EPS

● Terminal Configuration

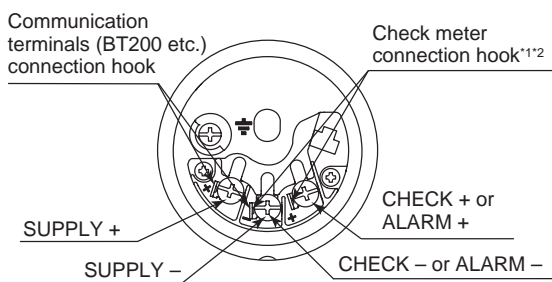

● Terminal Wiring

SUPPLY	+	Power supply and output terminal
CHECK	+	External indicator (ammeter) terminal*1*2
or	-	or
ALARM	+	Status contact output terminal*2
	-	(when /AL is specified)
	⏏	Ground terminal

*1: When using an external indicator or check meter, the internal resistance must be 10 Ω or less. A check meter or indicator cannot be connected when /AL option is specified.

*2: Not available for fieldbus communication type.

F04E.EPS

● Wiring Example for Analog Output and Status Output

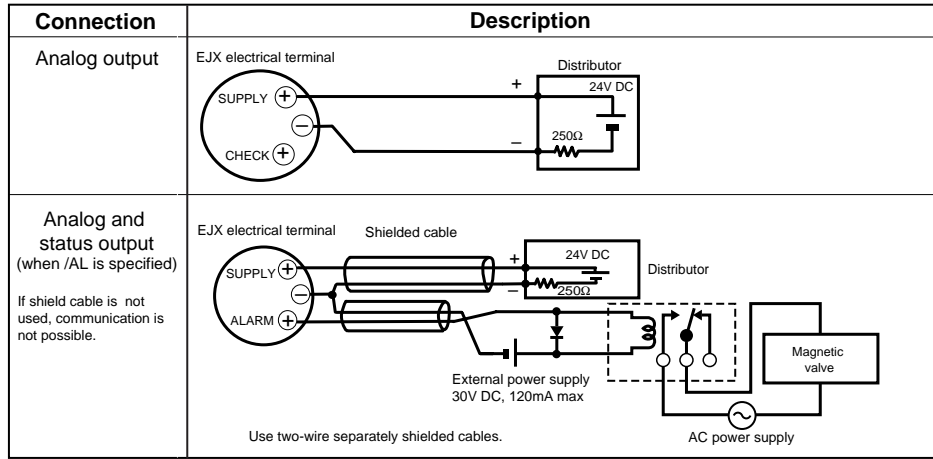

F05E.EPS

Table 1. Calibration Units

Measurement Span and Range	Optional Code			
	D1 (psi Unit)	D3 (bar Unit)	D4 (kgf/cm ² Unit)	
L	Span	4 to 40 inH ₂ O	10 to 100 mbar	100 to 1000 mmH ₂ O
	Range	0 to 40 inH ₂ O	0 to 100 mbar	0 to 1000 mmH ₂ O
M	Span	8 to 400 inH ₂ O	20 to 1000 mbar	200 to 10000 mmH ₂ O
	Range	0 to 400 inH ₂ O	0 to 1000 mbar	0 to 10000 mmH ₂ O
H	Span	80 to 830 inH ₂ O	200 to 2100 mbar	2000 to 21000 mmH ₂ O
	Range	0 to 830 inH ₂ O	0 to 2100 mbar	0 to 21000 mmH ₂ O

T11E.EPS

< Ordering Information > “◇”

Specify the following when ordering

1. Model, suffix codes, and option codes
2. Calibration range and units
 - 1) Calibration range can be specified with range value specifications up to 5 digits (excluding any decimal point) for low or high range limits within the range of -32000 to 32000. When reverse range is designated, specify Lower Range Value(LRV) as greater than Upper Range Value(URV). When square root output mode is specified, LRV must be “0 (zero) ”.
 - 2) Specify only one unit from the table, ‘Factory setting.’
3. Select linear or square root for output mode.

Note: If not specified, the instrument is shipped set for linear mode.
4. Display scale and units (for transmitters equipped with the integral indicator only)

Specify either 0 to 100 % or ‘Range and Unit’ for engineering units scale:
Scale range can be specified with range limit specifications up to 5 digits (excluding any decimal point) for low or high range limits within the range of -32000 to 32000. Unit display consists of 6-digit, therefore, if the specified scaling unit excluding ‘/’ is longer than 6-characters , the first 6 characters will be displayed on the unit display.
5. Tag Number (if required)

For BRAIN communication type, specify upto 16 letters. The specified letters will be written in the amplifier memory and engraved on the tag plate.
For HART communication type, specify software tag (up to 8 letters) to be written on the amplifier memory and Tag number(up to 16 letters) to be engraved on the tag plate separately.

6. Other factory configurations (if required)

Specifying option code **CA** or **CB** will allow further configuration at factory. Following are configurable items and setting range.

- [/CA : For HART communication type]
- 1) Descriptor(up to 16 characters)
 - 2) Message (up to 30 characters)
 - 3) Software damping in second (0.00 to 100.00)
- [/CB : For BRAIN communication type]
- 1) Software damping in second (0.00 to 100.00)
7. Necessary data for orifice calculations (integral orifice flow specifications), or required values for orifice bore and differential pressure range. Refer to TI 01C20K00-01E for details.

< Factory Setting > “◇”

Tag number	As specified in order
Software damping *1	‘2.00 sec’ or as specified in order
Output mode	‘Linear’ unless otherwise specified in order
Display mode	‘Square root’
Calibration range lower range value	As specified in order
Calibration range upper range value	As specified in order
Calibration range unit	Selected from mmH ₂ O, mmH ₂ O(68°F), mmAq ² , mmWG ² , mmHg, Pa, hPa ² , kPa, MPa, mbar, bar, gf/cm ² , kgf/cm ² , inH ₂ O, inH ₂ O(68°F), inHg, ftH ₂ O, ftH ₂ O(68°F) or psi. (Only one unit can be specified.)
Display setting	Designated differential pressure value specified in order. (% or user scaled value.)
Static pressure display range	0 to 16 MPa, absolute value. Measuring high pressure side.

T12E.EPS

*1: To specify these items at factory, option code **CA** or **CB** is required.

*2: Not available for HART protocol type.