

General Specifications

AXFA11G Magnetic Flowmeter Remote Converter



GS 01E20C01-01E

The AXFA11 magnetic flowmeter high grade remote converter is a sophisticated product with outstanding reliability and ease of operation, developed on the basis of decades of field-proven experience.

The AXFA11 employs an LCD indicator, infra-red switches, and "Easy Setup" parameters to ensure substantially improved ease of maintenance.

The combination of a replaceable electrode type flowtube and diagnostics to detect the adhesion level on the electrodes dramatically improves maintainability.

The AXFA11 also employs the fluid noise free "Dual Frequency Excitation Method" and the newly added "Enhanced Dual Frequency Excitation Method" as an option for more difficult applications to ensure greater stability and quicker response.

Note: The "Dual Frequency Excitation Method" is Yokogawa's unique technology.



FEATURES

User-oriented Functionality

Fluid Adhesion Level Diagnosis

By constantly monitoring the level of insulating substance on the electrodes, it is possible to determine when maintenance is required.

With the utilization of an optional replaceable electrode type flowtube, in cases of severe adhesion, the electrodes can be easily removed from the flowmeter and cleaned.

Clear and Versatile Indications

The LCD indicator employs a large, backlit full dot-matrix, that can facilitate various displays. One to three lines are available. When there is an alarm condition, a full description of the countermeasure is indicated.

"Easy Setup" Parameters

The most frequently used parameters are arranged in a group at the top. The infra-red switches enable the users to set parameters without opening the cover.

Operation Immediately after Installation

The AXFA11 is shipped with the main parameters completely set. Therefore, the AXFA11 can be operated immediately after installation and wiring.

Compact and Light-weight Amplifier

The AXFA11 is equipped with a compact and light-weight amplifier.

Expansion of Product Lineup

Improve Accuracy Specification

The standard accuracy is 0.35% of reading. Also available is an optional high accuracy calibration rated at 0.2% of reading.

Enhanced Performance and Specifications

Enhanced Dual Frequency Excitation Method

The "Enhanced Dual Frequency Excitation Method" can be optionally selected.

For difficult applications such as for high concentration slurries or low conductivity fluid, extremely stable measurements can be realized.

Improved Minimum Conductivity

The newly designed AXF converter permits the measurement of fluids with conductivity as low as 1µS/cm.

High-Speed Pulse Output

The pulse rate now goes up to 10,000 pps (pulse/second) for use with high speed applications such as in short time batch processes.

Versatile Input/output Function Now Available

The functions of one current output, one pulse output, one alarm output, two status inputs, and two status outputs are available.

CONTENTS

Features	P. 1
Standard Specifications	P. 2
Standard Performance	P. 4
Normal Operating Conditions	P. 5
Accessories	P. 5
Model and Suffix Code	P. 6
Optional Specifications for AXFA11 Remote Converter	P. 7
Terminal Configuration, Terminal Wiring	P. 7
External Dimensions	P. 8
Ordering Information	P.10

■ STANDARD SPECIFICATIONS

Excitation Method: (Combined with AXF Remote Flowtube)

- Standard dual frequency excitation:
Size 2.5 to 400 mm (0.1 to 16 in.)
- Enhanced dual frequency excitation:
Size 25 to 200 mm (1.0 to 8.0 in.)
(Optional code HF1 or HF2)
- Pulsed DC excitation:
Size 500 to 2600 mm (20 to 104 in.)

Input Signal:

Two Status Inputs: Dry contact
Load resistance: 200 Ω or less (ON), 100 kΩ or more (OFF)

Output Signals:

- One Current Output: 4 to 20 mA DC (load resistance: 1kΩ maximum, including cable resistance)
- One Pulse Output:
Transistor contact output (open collector)
Contact capacity: 30 V DC (OFF), 200 mA (ON)
Output rate: 0.0001 to 10,000 pps (pulse/second)
- One Alarm Output:
Transistor contact output (open collector)
Contact capacity: 30 V DC (OFF), 200 mA (ON)
- Two Status Outputs:
Transistor contact output (open collector)
Contact capacity: 30 V DC (OFF), 200 mA (ON)

Communication Signals:

BRAIN or HART communication signal
(Superimposed on the 4 to 20 mA DC signal)
Distance from Power Line: 15 cm (6 in.) or more
(Parallel wiring should be avoided.)

BRAIN:

Communication Distance:

Up to 2 km (1.25 miles), when polyethylene insulated PVC-sheathed cables (CEV cables) are used.
Communication distance varies depending on the type of cable and wiring used.

Load Resistance:

250 to 600 Ω (including cable resistance)

Load Capacitance:

0.22 μF or less

Load Inductance:

3.3 mH or less

Input Impedance of Communicating Device:

10 kΩ or more (at 24 kHz)

HART:

Communication Distance:

Up to 1.5 km (0.9 mile), when using multiple twisted pair cables. Communication distance varies depending on the type of cable used.

Load Resistance:

230 to 600 Ω (including cable resistance)

Cable Length for Specific Applications:

Use the following formula to determine the cable length for specific applications:

$$L = \frac{65 \times 10^6}{(R \times C)} - \frac{(C_f + 10,000)}{C}$$

where:

- L = length in meters or feet
- R = resistance in Ω (including barrier resistance)
- C = cable capacitance in pF/m or pF/ft
- C_f = maximum shunt capacitance of receiving devices in pF/m or pF/ft

Note: HART is a registered trademark of the HART Communication Foundation.

Data Security During Power Failure:

Data (parameters, totalizer value, etc.) storage by EEPROM. No back-up battery required.

Indicator:

Full dot-matrix LCD (32×132 pixels)

Lightning Protector:

The lightning protector is built into the excitation current output, the current output, the signal common, and the pulse/alarm/status input and output terminals. When optional code A is selected, the lightning protector is built into the power terminals.

Protection:

IP66, IP67, JIS C0920 immersion-proof type

Coating:

Case and Cover: Polyurethane corrosion-resistant
Coating Color: Silver gray (Munsell 3.2PB 7.4/1.2 or its equivalent)

Cover Mounting Screws: Polyurethane corrosion-resistant
Coating Color: Mint green (Munsell 5.6BG 3.3/2.9 or its equivalent)

Converter Material:

Case and Cover: Aluminum alloy

Mounting/Shapes:

- Mounting: 2-inch pipe, panel or surface mounting
- Electrical Connection: ANSI 1/2 NPT female
ISO M20 ×1.5 female
JIS G1/2 (PF1/2) female
- Terminal Connection: M4 size screw terminal

Grounding:

Grounding resistance 100 Ω or less
When optional code A is selected, grounding resistance 10 Ω or less shall be applied.

Combined Remote Flowtube:

- AXFA11 Converter can be combined with size 2.5 to 2600 mm (0.1 to 104 in.) of AXF Remote Flowtube. However, the AXFA11 converter cannot combine with AXF Remote Flowtube of TIIS flame proof type (In this case, use the AXFA14 converter).
- If a combined converter is changed from AXFA11 to AXFA14 or vice versa, a new meter factor must be adjusted by flow calibrations.

Functions

How to Set Parameters:

The indicator's LCD and three infra-red switches enable users to set parameters without opening the case cover. Parameters can also be set by means of the HHT(Hand-held terminal).

Displayed Languages:

Users can choose a language from among English, Japanese, German, French, Italian, Spanish.

Instantaneous Flow Rate/Totalized Value Display Functions:

The full dot-matrix LCD enables user selections of displays from one line to three lines for:

- Instantaneous flow rate
- Instantaneous flow rate (%)
- Instantaneous flow rate (bar graph)
- Current output value (mA)
- Totalized value
- Tag No.
- Results of electrode adhesion diagnostics

Totalizer Display Function:

The flow rate is counted one pulse at a time according to the setting of totalization pulse weights. For forward and reverse flow measurement functions, the totalized values of the flow direction (forward or reverse) and the flow direction are displayed on the indicator together with the units. The difference of totalized values between the forward and reverse flow rate can be displayed. Totalization for the reverse flow rate is carried out only when "Forward and reverse flow measurement functions" is selected.

Damping Time Constant:

Time constant can be set from 0.1 second to 200.0 seconds (63% response).

Span Setting Function:

Span flows can be set in units such as volume flow rate, mass flow rate, time, or flow rate value. The velocity unit can also be set.

Volume Flow Rate Unit: kcf, cf, mcf, Mgal (US), kgal (US), gal (US), mgal (US), kbbbl (US)*, bbl (US)*, mbbbl (US)*, μbbbl (US)*, MI (megaliter), m³, kl (kiloliter), l (liter), cm³

Mass Flow Rate Unit (Density must be set.): klb (US), lb (US), t (ton), kg, g

Velocity Unit: ft, m (meter)

Time Unit: s (sec), min, h (hour), d (day)

* "US Oil" or "US Beer" can be selected.

Pulse Output:

Scaled pulse can be output by setting a pulse weight.

Pulse Width: Duty 50% or fixed pulse width (0.05, 0.1, 0.5, 1, 20, 33, 50, 100 ms) can be selected.

Output Rate: 0.0001 to 10,000 pps (pulse/second)

Multi-range Function:

- Range switching via status input
Status input enables the switching of up to four ranges.
- Automatic range switching
When the flow rate exceeds 100 % of the range, transition to the next range (up to four ranges) is carried out automatically. Range switching can be confirmed by status outputs and indicator.

Forward and Reverse Flow Measurement Functions:

Flows in both forward and reverse directions can be measured. The reverse flow measurement can be confirmed by status output and indicator.

Totalization Switch:

The status output is carried out when a totalized value becomes equal to or greater than the set value.

Preset Totalization:

The parameter setting or status input enables a totalized value to be preset to a setting value or zero.

0% Signal Lock:

Status input forcibly fixes the instantaneous flow rate display, current output, pulse output, and flow rate totalization to 0%.

Alarm Selection Function:

Alarms are classified into System Alarms (hard failures), Process Alarms (such as 'Empty Pipe', 'Signal Overflow' and 'Adhesion Alarm'), Setting Alarms, and Warnings. Whether alarms should be generated or not can be selected for each item.

The current output generated for an alarm can be selected from among 2.4 mA or less, fixed to 4 mA, 21.6 mA or more, or HOLD.

Alarm Output:

Alarms are generated only for the items selected via the 'Alarm Selection Function' if relevant failures occur.

Self Diagnostics Functions:

If alarms are generated, details of the System Alarms, Process Alarms, Setting Alarms and Warnings are displayed together with concrete descriptions of countermeasures.

Flow Upper/Lower Limit Alarms:

If a flow rate becomes greater or smaller than the set value, this alarm is generated. In addition, two upper limits (H, HH) and two lower limits (L, LL) can be set. If a flow rate becomes greater or smaller than any of the set values, the status is output.

Electrode Adhesion Diagnostics Function:

This function enables monitoring of the adhesion level of insulating substances to the electrodes. Depending on the status of adhesion, users are notified by a warning or an alarm via status outputs. If replaceable electrodes are used, they can be removed and cleaned when adhesion occurs.

STANDARD PERFORMANCE

Reference Conditions:

- Similar to BS EN 29104 (1993); ISO9104 (1991)
- Fluid Temperature: 20°C ±10°C (+68°F ±18°F)
- Ambient Temperature: 25°C ±5°C (+77°F ±9°F)
- Warm-up Time: 30 min
- Straight runs
 - Upstream > 10 × DN
 - Downstream > 5 × DN
- Properly grounded
- Properly centered

Accuracy (Combined with AXF Remote Flowtube, at reference conditions)

Pulse Output:

PFA/Ceramics Lining:

Size mm (in.)	Flow Velocity V m/s (ft/s)	Standard Accuracy (Calibration code B)	Flow Velocity V m/s (ft/s)	High grade Accuracy (Calibration code C)
2.5 (0.1) to 15 (0.5)	V < 0.3 (1)	±1.0 mm/s	—	—
	0.3 ≤ V ≤ 10 (1) (33)	±0.35% of Rate		
25 (1.0) to 200 (8.0)	V < 0.15 (0.5)	±0.5 mm/s	V < 0.15 (0.5)	±0.5 mm/s
	0.15 ≤ V ≤ 10 (0.5) (33)	±0.35% of Rate	0.15 ≤ V < 1 (0.5) (3.3)	±0.18% of Rate ±0.2mm/s
			1 ≤ V ≤ 10 (3.3) (33)	±0.2% of Rate
250 (10) to 400 (16)	V < 0.15 (0.5)	±0.5 mm/s	—	—
	0.15 ≤ V ≤ 10 (0.5) (33)	±0.35% of Rate		

Enhanced dual frequency excitation (Option code HF2) : T01.EPS
Standard accuracy ± 1 mm/s

Size 2.5 mm (0.1 in.) to 15 mm (0.5 in.)

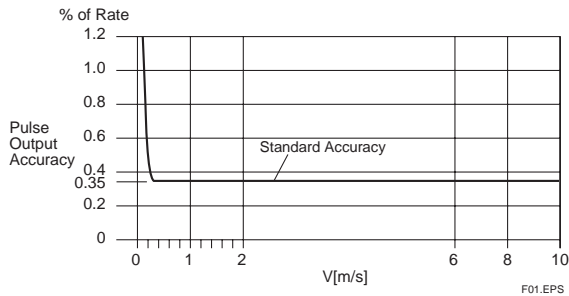

Size 25 mm (1.0 in.) to 400 mm (16 in.)

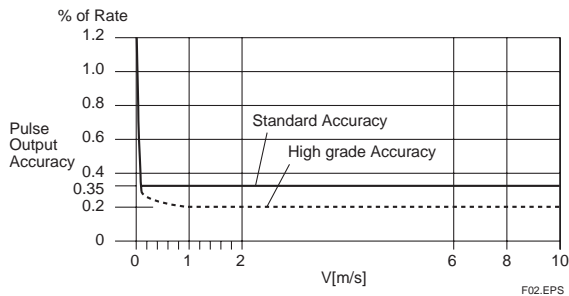

Polyurethane Rubber/Natural Soft Rubber/EPDM Rubber Lining

Size mm (in.)	Flow Velocity V m/s (ft/s)	Standard Accuracy (Calibration code B)
25 (1.0) to 400 (16)	V < 0.3 (1.0)	±1.0 mm/s
	0.3 ≤ V ≤ 10 (1.0) (33)	±0.35% of Rate
500 (20) to 1000 (40)	V < 0.3 (1.0)	±1.75 mm/s
	0.3 ≤ V < 1 (1.0) (3.3)	±0.25% of Rate ±1 mm/s
		1 ≤ V ≤ 10 (3.3) (33)
1100 (44) to 2000 (80)	V < 0.3 (1.0)	±2.2 mm/s
	0.3 ≤ V < 1 (1.0) (3.3)	±0.4% of Rate ±1 mm/s
		1 ≤ V ≤ 10 (3.3) (33)
2200 (88) to 2600 (104)	V < 1 (3.3)	±8.5 mm/s
	1 ≤ V ≤ 10 (3.3) (33)	±0.85% of Rate

Enhanced dual frequency excitation (Option code HF2) : T02.EPS
Standard accuracy ± 1 mm/s

Size 25 mm (1.0 in.) to 400 mm (16 in.)

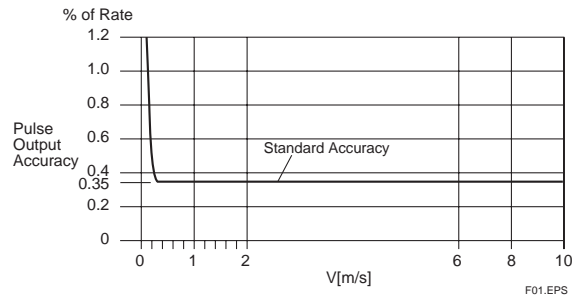

Size 500 mm (20 in.) to 1000 mm (40 in.)

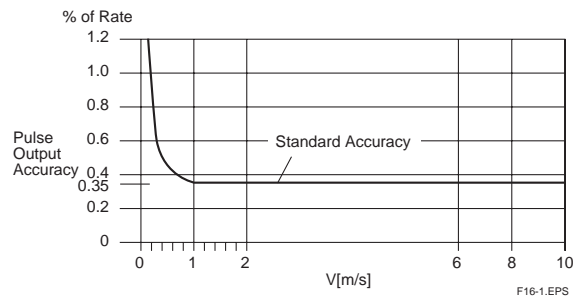

Size 1100 mm (44 in.) to 2000 mm (80 in.)

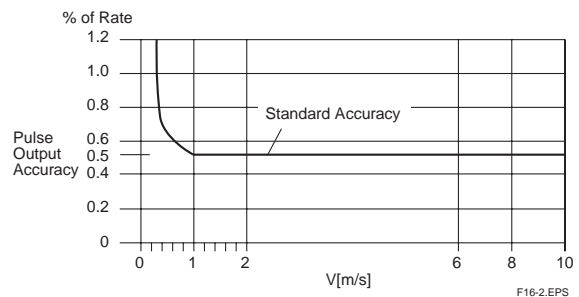

Size 2200 mm (88 in.) to 2600 mm (104 in.)

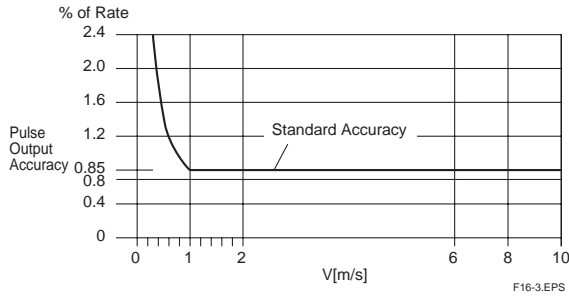

Current Output: Pulse output accuracy plus $\pm 0.05\%$ of Span

Repeatability:

- $\pm 0.1\%$ of Rate ($V \geq 1$ m/s (3.3 ft/s))
- $\pm 0.05\%$ of Rate ± 0.5 mm/s ($V < 1$ m/s (3.3 ft/s))

Maximum Power Consumption:

Combined with AXF Remote Flowtube: 20 W

Insulation Resistance(*1) :

- Between power supply terminals and ground terminal: 100M Ω at 500V DC
- Between power supply terminals and input/output/excitation current terminals : 100M Ω at 500V DC
- Between ground terminal and input/output/excitation current terminals: 20M Ω at 100V DC
- Between input/output/excitation current terminal: 20M Ω at 100V DC

Withstand Voltage(*1) :

- Between power supply terminals and ground terminal: 1390V AC for 2 seconds
- Between power supply terminals and input/output terminals: 1390V AC for 2 seconds
- Between excitation current terminal and ground terminal: 160V AC for 2 seconds
- Between excitation current terminal and input /output terminals: 200V AC for 2 seconds



CAUTION

*1: When performing the Insulation Resistance Test or the Withstand Voltage Test, please obey the following caution.

- Following the relevant test, wait for more than 10 seconds after the power supply has been turned off before removing the cover.
- Remove all wires from terminals before testing.
- When the power terminal has a lighting protector (optional code A), remove the short bar at the ground terminal.
- After testing, be sure to discharge by using a resistance and return all wires and the short bar to its correct position.
- Screws must be tightened to a torque of 1.18 N-m or more.
- After closing the cover, the power supply can be restored.

Safety Requirement Standards:

- EN61010-1
- Altitude at installation site: Max. 2000 m above sea level

- Installation category based on IEC1010: Overvoltage category II ("II" applies to electrical equipment which is supplied from a fixed installation-like distribution board.)
- Pollution degree based on IEC1010 Pollution degree 2 ("Pollution degree" describes the degree to which a solid, liquid, or gas which deteriorates dielectric strength or surface resistivity is adhering. "2" applies to a normal indoor atmosphere.)

EMC Conformity Standards:

- EN61326
- EN61000-3-2, EN61000-3-3
- AS/NZS CISPR11

■ NORMAL OPERATING CONDITIONS

Ambient Temperature: -40°C to $+60^{\circ}\text{C}$ (-40°F to $+140^{\circ}\text{F}$)

Indicator's operating range: -20°C to $+60^{\circ}\text{C}$ (-4°F to $+140^{\circ}\text{F}$)

Ambient Humidity: 0 to 100%

Lengthy continuous operation at 95% or more is not recommended.

Power Supply:

Power supply code 1:

- AC specifications
Rated power supply: 100 to 240 V AC, 50/60 Hz
(Operating voltage range: 80 to 264 V AC)
- DC specifications
Rated power supply: 100 to 120 V DC
(Operating voltage range: 90 to 130 V DC)

Power supply code 2:

- AC specifications
Rated power supply: 24 V AC, 50/60 Hz
(Operating voltage range: 20.4 to 28.8 V AC)
- DC specifications
Rated power supply: 24 V DC
(Operating voltage range: 20.4 to 28.8 V DC)

Supplied Power and Cable Length for Power Supply Code 2

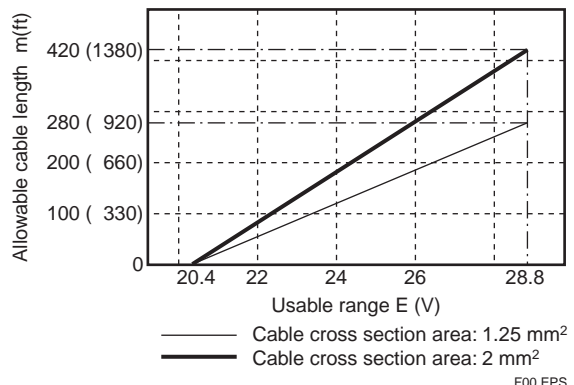

Vibration Conditions:

Level of vibration in conformity with IEC 60068-2-6 (SAMA31. 1-1980)

0.5 G or less (frequency 500 Hz or less)

Note: Avoid locations with much vibration (with a vibration frequency of 500 Hz or more), which may cause damage to the equipment.

■ ACCESSORIES

- Fuse (Time lag fuse): 1 pc.
- Power supply code 1; T2.5 A, 250 V
 - Power supply code 2; T3.15A, 250 V
- Mounting bracket: 1 set

■ MODEL AND SUFFIX CODE

AXFA11 Magnetic Flowmeter Remote Converter:

Model	Suffix Code	Description
AXFA11		Magnetic Flowmeter Remote Converter
Use	G	General-Purpose Use For AXF Remote Flowtube of size 2.5 to 2600 mm (0.1 in. to 104 in.)
Output Signal and Communication	-D	4 to 20 mA DC, BRAIN Communication
	-E	4 to 20 mA DC, HART Communication
Power Supply	1	100 V to 240 V AC or 100 to 120 V DC
	2	24 V AC/DC (*1)
Electrical Connections	-0	JIS G1/2 female
	-2	ANSI 1/2 NPT female
	-4	ISO M20 × 1.5 female
Indicator	1	With Indicator
Option	/□	Optional code (See the Table of Optional Specifications)

T03.EPS

*1: In case of power supply code 2 (24 V AC/DC), optional code A (lighting protector) is mandatory.

Signal Cable:

Model	Suffix Code	Description
AXFC	Magnetic Flowmeter Dedicated Signal cable for the ADMAG AXF series
Termination	-0	No Termination. A set of termination parts for M4 screws is attached.
	-4	Terminated for the AXFA11/14 Converter.
Cable Length	-L□□□	Designate the cable length, unit: m Following "L", specify the cable in three digits as multiple of 1 meter (e.g., 001, 002, or 005) for a length up to 5 m, or as a multiple of 5 meters (i.e., 005, 010, 015, or the like). The maximum cable length: 200 m for combined use with AXFA11 100 m for combined use with AXFA14
Option	/C□	With termination parts sets. Following "C", specify the q'ty of sets of termination parts in one digits.

T04.EPS

- Note:
- The cable is constructed with double shielding over the two conductors, and uses heat-resistant vinyl as the outer covering material.
Finished diameter: 10.5 mm (0.413 in.)
Maximum temperature: +80°C (+176°F)
 - Unnecessary to order the above cable for submersible type flowtube or for the optional code DHC flowtube because the flowtube is wired with 30 m (98 ft) cable.
 - For excitation cable, prepare a two-core cable at the customer side.

Recommended Excitation, Power and Output Cable:

Use Polyvinyl chloride insulated and sheathed control cable (JIS C3401) or Polyvinyl chloride insulated and sheathed portable power cables (JIS C3312) or equivalents.

- Outer Diameter: 6.5 to 12 mm (0.26 to 0.47 in.)
7.5 to 12 mm (0.30 to 0.47 in.) for optional code EG, EU and EW
6 to 12 mm (0.24 to 0.47 in.) for optional code EP
- Nominal Cross Section(single wire): 0.5 to 2.5 mm²
- Nominal Cross Section(standard wire): 0.5 to 1.5 mm²

OPTIONAL SPECIFICATIONS FOR AXFA11 REMOTE CONVERTER

Item	Specification	Code
Lightning Protector	A lightning protector is built into the power terminals. In case of power supply code 2 (24 V AC/DC), this optional code is mandatory.	A
DC Noise Cut Circuit	The DC Noise Cut Circuit is built in. Available for 15 mm (0.5 in.) and larger sizes, and for fluids with the conductivity of 50 μS/cm or higher. Nullifies the empty check and electrode adhesion diagnostics function.	ELC
Burn Out Down	The output level is set to 0 mA during a CPU failure and is set 2.4 mA (-10%) or less during an alarm. Standard products are delivered with a setting 25 mA during a CPU failure and 21.6 mA (110%) or more during an alarm.	C1
NAMUR NE43 Compliance	Output signal limits: 3.8 to 20.5 mA	C2
	Failure alarm down-scale: The output level is set to 0 mA during a CPU failure and is set 2.4 mA (-10%) or less during an alarm. Failure alarm up-scale: The output level is set to 25 mA during a CPU failure and is set 21.6 mA (110%) or more during an alarm.	C3
Active Pulse Output	Active pulses are output in order to drive an external electromagnetic or electronic counter directly using the converter's internal power supply. (Nullifies the standard transistor contact pulse output.) Output voltage: 24 V DC ±20% Pulse specifications: • The drive current of 30 to 150 mA • Pulse rate: 0.0001 to 2 pps (pulse/second); Pulse width: 20, 33, 50, or 100 ms	EM
G3/4 Female Waterproof Glands	Waterproof glands for G3/4 conduits or flexible tubes are attached to the electrical connections. Available only for JIS G1/2 electric connections.	EW
Waterproof Glands	Waterproof glands are attached to the electrical connections. Available only for JIS G1/2 electric connections.	EG
Waterproof Glands with Union Joints	Waterproof glands with union joints are attached to the electrical connections. Available only for JIS G1/2 electric connections.	EU
Plastic Glands	Plastic glands are attached to the electrical connections. Available only for JIS G1/2 electric connections.	EP
Air Purge Fitting	Provided with an air purge fitting (1.5 L/min air consumption) with purge air pressure at 0.14 MPa or less. 1/4 NPT female (when electrical conn. code is 2 or 4) or Rc1/4 (PT 1/4) female (when electrical conn. code is 0).	APC
Stainless Steel Mounting Bracket	Provided with a JIS SUS304 (AISI 304 SS/EN 1.4301 equivalent) stainless steel mounting bracket in lieu of the standard carbon steel bracket.	SB
AM11 Replacement Bracket	Provided with a special mounting bracket for replacing an AM11 converter with an AXFA11.	RK
Stainless Steel Tag Plate	Screwed JIS SUS304 (AISI 304 SS/EN 1.4301 equivalent) stainless steel tag plate. Choose this option when an SS tag plate is required in addition to the standard nameplate with the tag number inscribed on it. Dimension (Height × Width): Appr. 12.5 (4.92) × 40 (15.7) mm (inch)	SCT
Painting Color Change	Coated in black (Munsell N1.5 or its equivalent.)	P1
	Coated in jade green (Munsell 7.5BG4/1.5 or its equivalent.)	P2
	Coated in metallic silver.	P7
Epoxy Resin Coating	Epoxy resin coating which has alkali-resistance instead of standard polyurethane resin coating. The color is same as standard type.	X1
High Anti-corrosion Coating	Three-layer coating (polyurethane coating on two-layer epoxy resin coating) in the same range as that for the standard coating. The color is same as standard type. Salt/alkali/acid/weather-	X2
Calibration Certificate	Level 2: The Declaration and the Calibration Equipment List are issued.	L2
	Level 3: The Declaration and the Primary Standard List are issued.	L3
	Level 4: The Declaration and the Yokogawa Measuring Instruments Control System are issued.	L4

T05.EPS

● Terminal Configuration

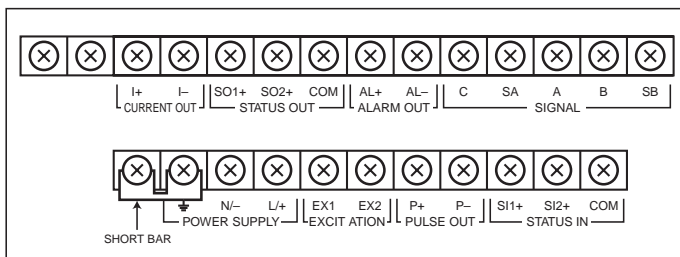

T06.EPS

● Terminal Wiring

Terminal Symbols	Description	Terminal Symbols	Description
SIGNAL ┌ C ├ SA ├ A ├ B └ SB	Flow signal input	STATUS IN ┌ SI1+ ├ SI2+ └ COM	Status input (Two input)
ALARM OUT ┌ AL+ └ AL-	Alarm output	PULSE OUT ┌ P+ └ P-	Pulse output
STATUS OUT ┌ SO1+ ├ SO2+ └ COM	Status output (Two output)	EXCITATION ┌ EX1 └ EX2	Excitation current output
CURRENT OUT ┌ I+ └ I-	Current output 4 to 20mA DC	POWER SUPPLY ┌ L/+ └ N/-	Power supply
		┌ └	Functional grounding
		⊕	Protective grounding (Outside of the terminal)

T07.EPS

EXTERNAL DIMENSIONS

Remote Converter AXFA11G

Unit: mm
(approx. inch)

Pipe mounting

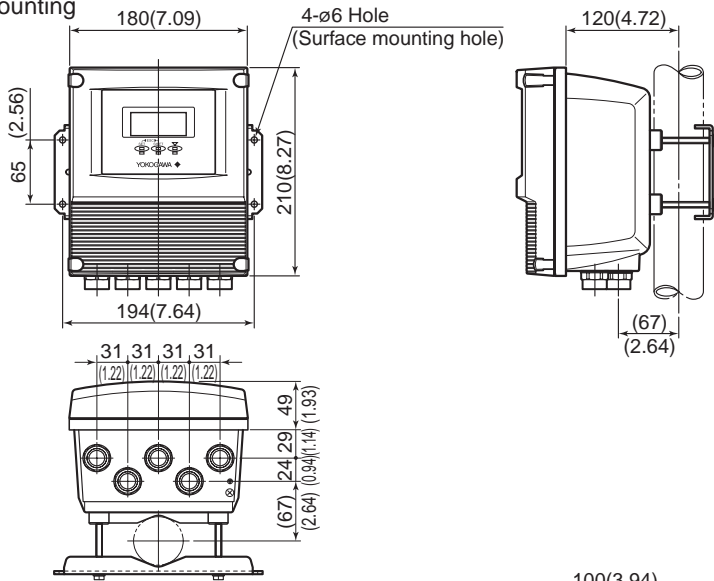

Weight 3.3 kg (7.3 lb)

Panel mounting

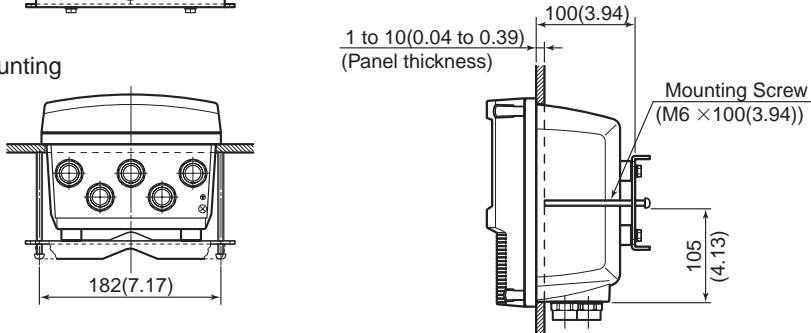

Surface mounting

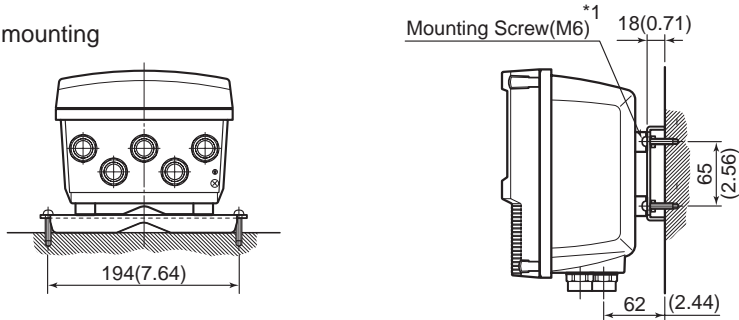

*1: These screws must be provided by the user.

T08.EPS

● Remote Converter AXFA11G /RK (AM11 Replacement Bracket)

Pipe mounting

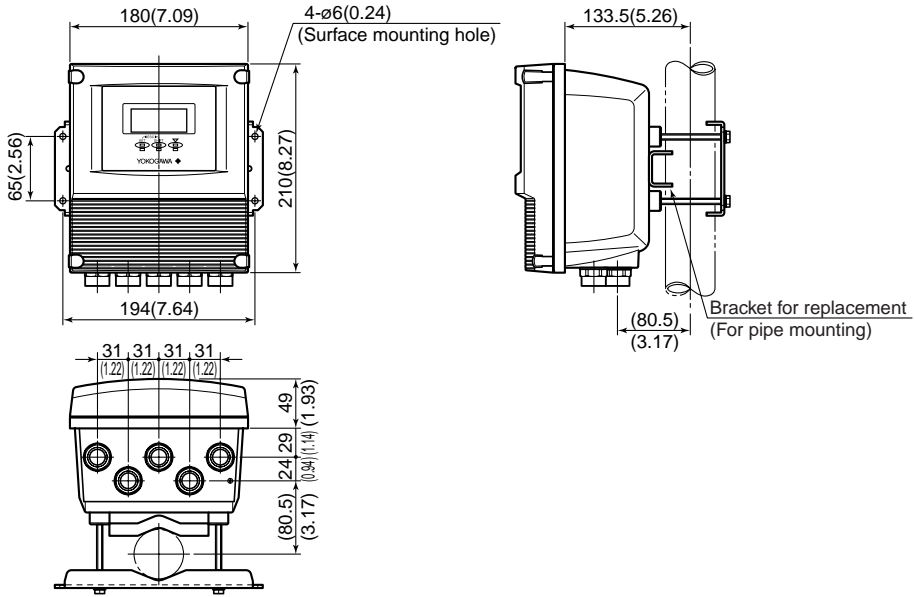

Surface mounting

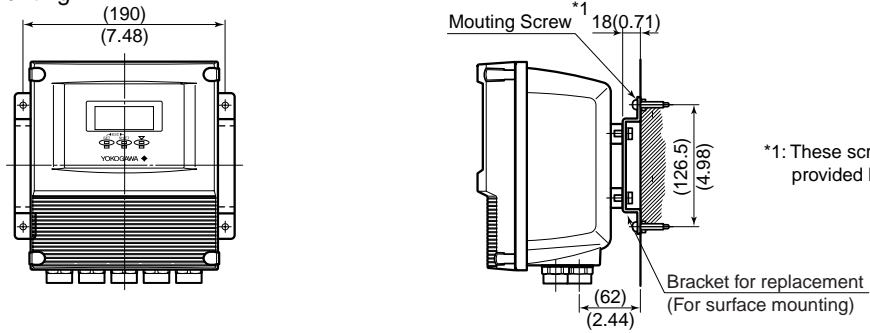

FF0AXFA11E.EPS

● Unless otherwise specified, difference in the dimensions are refer to the following table.

General tolerance in the dimensional outline drawing.

Unit : mm (approx.inch)

Category of basic dimension		Tolerance	Category of basic dimension		Tolerance
Above	Equal or below		Above	Equal or below	
	3 (0.12)	±0.7 (±0.03)	500 (19.69)	630 (24.80)	±5.5 (±2.17)
3 (0.12)	6 (0.24)	±0.9 (±0.04)	630 (24.80)	800 (31.50)	±6.25 (±0.25)
6 (0.24)	10 (0.39)	±1.1 (±0.04)	800 (31.50)	1000 (39.37)	±7.0 (±0.28)
10 (0.39)	18 (0.71)	±1.35 (±0.05)	1000 (39.37)	1250 (49.21)	±8.25 (±0.32)
18 (0.71)	30 (1.18)	±1.65 (±0.06)	1250 (49.21)	1600 (62.99)	±9.75 (±0.38)
30 (1.18)	50 (1.97)	±1.95 (±0.08)	1600 (62.99)	2000 (78.74)	±11.5 (±0.45)
50 (1.97)	80 (3.15)	±2.3 (±0.09)	2000 (78.74)	2500 (98.43)	±14.0 (±0.55)
80 (3.15)	120 (4.72)	±2.7 (±0.11)	2500 (98.43)	3150 (124.02)	±16.5 (±0.65)
120 (4.72)	180 (7.09)	±3.15 (±0.12)			
180 (7.09)	250 (9.84)	±3.6 (±0.14)			
250 (9.84)	315 (12.40)	±4.05 (±0.16)			
315 (12.40)	400 (15.75)	±4.45 (±0.18)			
400 (15.75)	500 (19.69)	±4.85 (±0.19)			

Remarks: The numeric is based on criteria of tolerance class IT18 in JIS B 0401.

● Dedicated Signal Cable

AXFC-4-L□□□

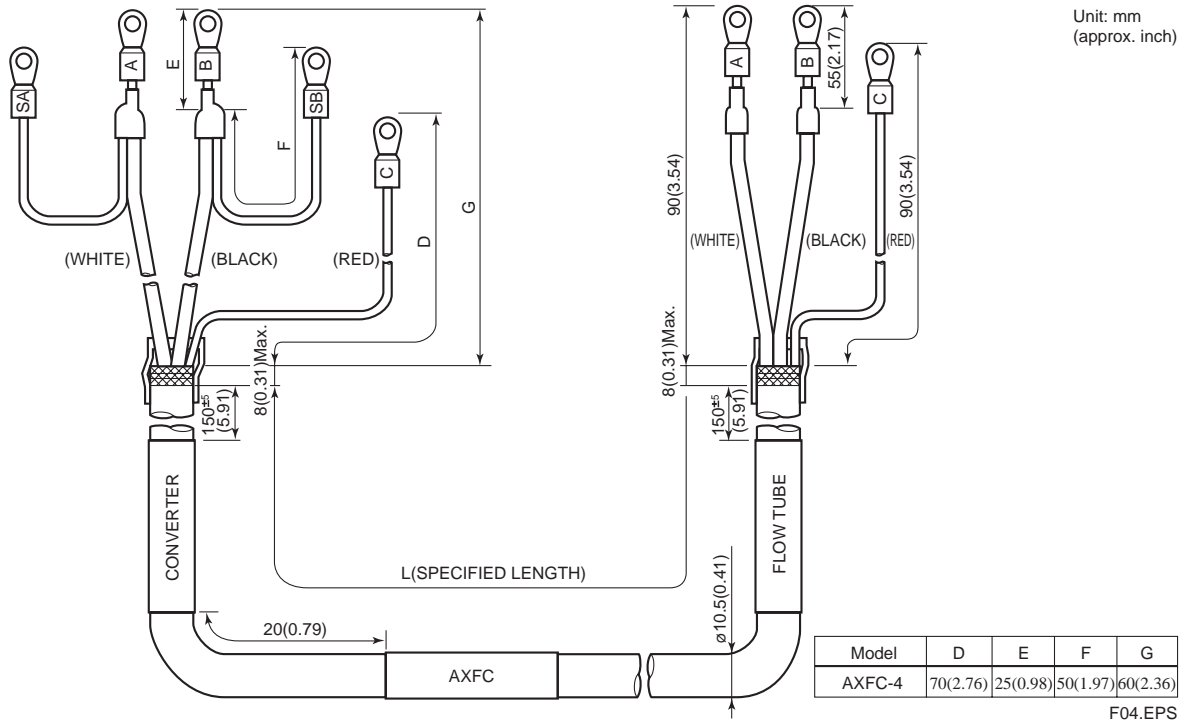

AXFC-0-L□□□

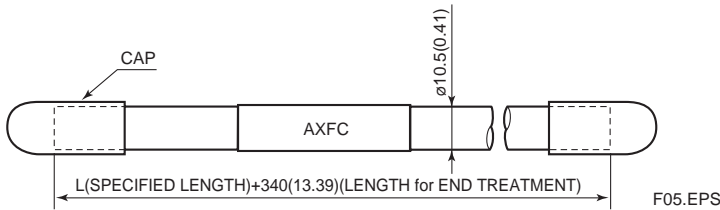

ORDERING INFORMATION

- Note 1: When ordering a remote flowtube and a remote converter, specify the flow span, unit, pulse weight, and totalizer display pulse weight for the order details of the flowtube. These parameters will then be set in the combined converter before shipment. Please refer to GS01E20D01-01E "ORDERING INFORMATION".
- Note 2: Some options, if ordered, require the relevant specifications to be input when ordering.

1. Model, specification and option codes.
2. Tag number

Each tag number can be specified in up to 16 characters in a combination of letters (capital or small letters), numbers, "-" and ".".

For HART protocol, up to 8 characters can be specified. If specified, the tag number is inscribed on the product's name plate and tag plate (if optional code SCT is selected). The tag number is also set into the memory of converter.

If the user wishes to change only the tag number to be set into a converter's memory, specify the software tag. If a tag number is not specified, the tag number is set as a blank.

RELATED INSTRUMENTS

- Calibrator for Magnetic Flowmeter (AM012): GS 01E06K02-00E
- BT200 Brain Terminal: GS 1C0A11-E
- AXF Magnetic Flowmeter Integral Flowmeter/ Remote Flowtube: GS 01E20D01-01E
- AXFA14G/C Magnetic Flowmeter Remote Converter: GS 01E20C02-01E