

General Specifications

MULCOM 2.0 Multiple Protocol Communication Interface

ProSafe-COM

GS 48J01A00-00E-N



Figure 1 Hardware platform CO-960-02/A2 for MULCOM 2.0

MULCOM, shown in figure 1, is a multiple protocol communication interface that connects the ProSafe-PLC and/or ProSafe-SLS safety system and/or any Modbus slave station to a CENTUM CS3000 with V-net (see figure 2). MULCOM also supports interfacing to OPC enabled DCS and SCADA systems through the use of the OPC (see figure 3).

Supported features are:

- Direct CENTUM CS3000 V-net interface for data exchange (boolean and analog) and event reporting.
- OPC Data Access (DA) server for data exchange (boolean and analog).
- OPC Alarm and Event (A&E) server for event reporting.
- Modbus slave interface for MULCOM configuration and for data and event exchange with the COM-SET (used as MULCOM System Engineering Tool). COM-SET and MULCOM also support the Modbus/TCP interface.
- Modbus master interface with external equipment (foreign PLC, etc.).
- Integrated sequence of events recorder, tracking events in the safety system with millisecond resolution, depending on the used data acquisition area.

- Handling of control signals from CENTUM CS3000 to the Safety Control Station, e.g. resets, start-up and maintenance overrides, etc.
- Execution of non-safety related logic.

The **basic MULCOM** is provided with:

- Two serial communication ports COM 1 and COM 2 based on RS-232, used to connect to:
 - the COM-SET system engineering tool
 - Modbus master/slave station(s)
 - an external modem for remote maintenance.
- Two Ethernet connections to support network protocols common to Windows 2000. By default Administrative Access is provided.
- A parallel interface for connection of a local line printer.

The next **Host interfaces** can be chosen:

- V-net interface card for connection to the CS3000 V-net
- OPC DA and AE server running connected through the Ethernet connections
- Modbus slave interface (DCS having a Modbus master interface). Both serial COM port and Modbus/TCP via Ethernet are supported.

The following **Data Acquisition interfaces** can be chosen:

- M-NET/M-BUS interface card for connection to the ProSafe-PLC network
- Y-net interface card for connection to ProSafe-SLS and/or matrix panel.
- Modbus master interface (external equipment having Modbus slave interfaces). Both serial COM port and Modbus/TCP via Ethernet are supported.

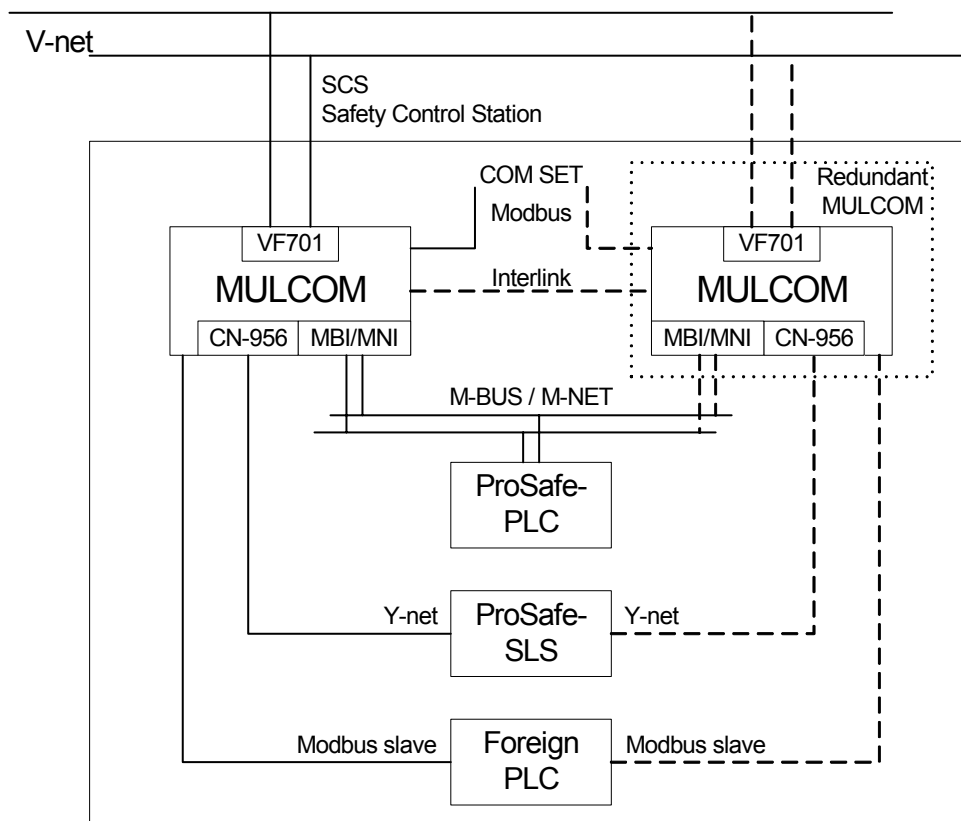

Figure 2 Typical CENTUM CS3000 – MULCOM – Safety System combination

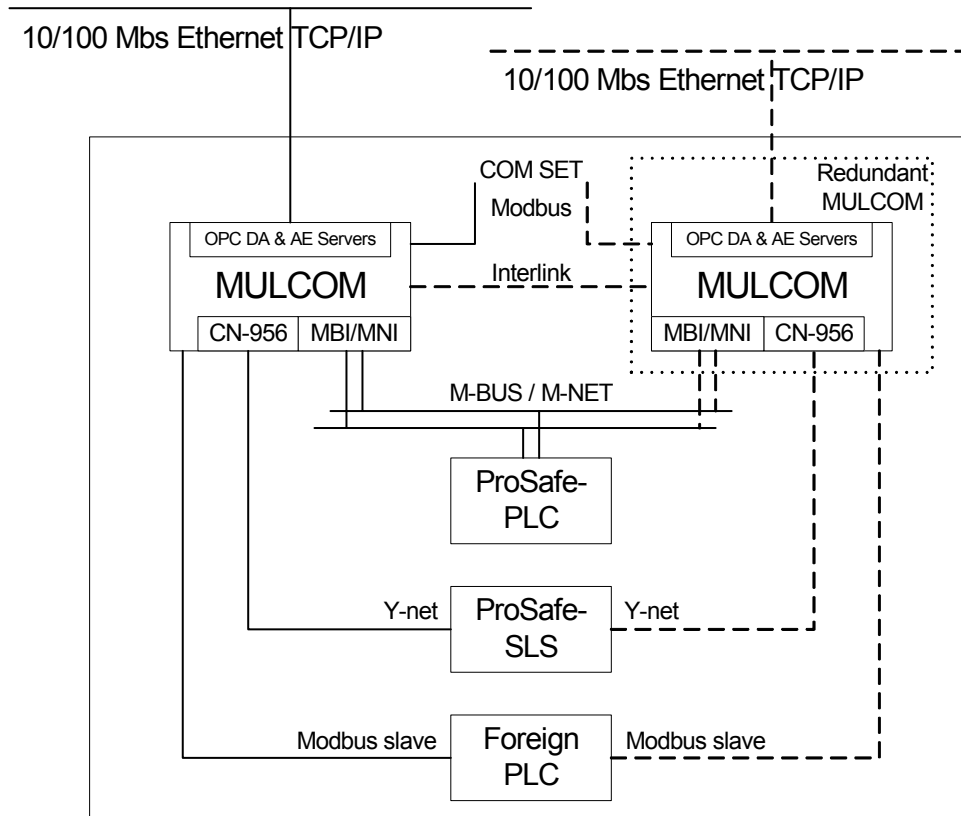

Figure 3 Typical OPC enabled DCS or SCADA – MULCOM – Safety System combination

■ Hardware interfaces

V-net Interface to CENTUM CS3000

The V-net interface board (VF701) connects to the proprietary dual token bus network of the CENTUM CS3000.

The MULCOM acts as a slave to read or write requests from the CENTUM CS3000. The following data can be read or written by the CENTUM CS3000:

- Digital (boolean) Input Status
- Digital (boolean) Output Status
- Analog Input Value: 16 and 32 bits signed and unsigned integer values and 32 and 64 bits floating point values
- Analog Output Value: 16 and 32 bits signed and unsigned integer values and 32 and 64 bits floating point values

Time stamped event messages are automatically broadcasted on the V-net by MULCOM.

Ethernet Interface

The Ethernet interfaces are used to provide an OPC DA and AE server interface to OPC enabled DCS and SCADA systems.

The OPC DA and AE servers on the Ethernet interface support the OPC Data Access Standard 2.0 and the Alarm and Event standard 1.0. The optional DA Data Item Browse interface is fully supported. Therefore the DA server is a fully self-revealing server. The Alarm and Event server is a so called "Simple Event Server."

The Data Access server supports the standard set of OPC functions for reading and writing Boolean and Analog Data Items (Tags). The following data types can be read or written:

- Digital (boolean) input status: Boolean with data status.
- Digital (boolean) output status: Boolean.
- Analog input value: Two- and four-byte signed and unsigned integers with data status, single and double precision floating point with data status.
- Analog output value: Two- and four-byte signed and unsigned integers, single and

double precision floating point with data status.

Alarm and Event Server attributes supported:

- Tag Name, UTC TimeStamp, Event Type ("Simple"), Severity, Tag description.

Note: The event line-format depends on the OPC Alarm and Event client used.

The Ethernet interface can also be used to connect MULCOM to a network to allow file transfer and easy software maintenance.

COM-SET and MULCOM both support the Modbus/TCP interface for MULCOM engineering and monitoring via a network (either Ethernet or V-net). Both Modbus master and slave are supported via Modbus/TCP.

A dedicated Ethernet connection is used for MULCOM redundancy.

Serial interface

The serial interfaces of MULCOM (the COM ports 1 up to 10) support the ModBus RTU interface. Both Modbus master and Modbus slave are supported.

Modbus slave:

The standard set of ModBus functions for reading and writing coils, registers and floats is implemented. Special ModBus function codes allow retrieval of time stamped event messages and support MULCOM engineering with COM-SET. The MULCOM acts as a ModBus slave on read or write requests from a ModBus master station (DCS or COM-SET). The following data can be read or written:

- MULCOM Data Files: Download MULCOM configuration files and upload error log files
- Digital (boolean) Input Status: single or multiple coils
- Digital (boolean) Output Status: single or multiple coils
- Register Input: single or multiple 16 bit registers containing analog or packed binary data, single precision (32-bits) floats
- Register Output: single or multiple 16 bit registers containing analog or packed binary data and 32-bits floats

Modbus master:

MULCOM's Modbus master supports the standard set of function codes for reading and writing coils and registers.

ProSafe-PLC Interface

MULCOM directly interfaces to the ProSafe-PLC's proprietary dual token bus network. Depending on the size and topology of the ProSafe-PLC safety system either an M-NET or M-BUS connection is used. The functionality is exactly the same from MULCOM's point of view. The following types of data can be transported via the M-NET and M-BUS networks:

- Digital (boolean) Input Status: bit status from ProSafe-PLC to MULCOM
- Digital (boolean) Output Status: bit status from MULCOM to ProSafe-PLC
- Analog Input Value: 16 and 32 bits signed and unsigned integer values and 32 and 64 bits floating point values from ProSafe-PLC to MULCOM
- Analog Output Value: 16 and 32 bits signed and unsigned integer values and 32 and 64 bits floating point values from MULCOM to ProSafe-PLC
- Time Stamped Event Messages: event messages from ProSafe-PLC to MULCOM
- Time Distribution: synchronise time from MULCOM to ProSafe-PLC

Y-net interface

- The Y-net interface board CN-956 connects MULCOM to a ProSafe-SLS safety system and to an operator's matrix panel. Y-net is a high speed proprietary communication network based on RS-485. Bus repeaters are available to achieve galvanic isolation of network segments or to cover distances up to 15 kilometers. The following types of data can be transported via the Y-net network(s):
- Digital (boolean) input status: Bit status from ProSafe-SLS to MULCOM.
- Digital (boolean) output status: Bit status from MULCOM to ProSafe-SLS.
- Analog input value: 8 bits analog values from ProSafe-SLS to MULCOM.

- Time stamped event messages: Event messages (msec resolution) from ProSafe-SLS or matrix panel to MULCOM.

■ Sequence of Event Recording

The ProSafe safety system generates two categories of time stamped events:

- Diagnostic Event Messages: Their intention is to alert the system operator of hardware and software malfunctions of the ProSafe safety system. This category of event messages appears on the system alarm overview of the CENTUM CS3000 HIS station(s).
- Process Event Messages: These event messages mark changes in physical I/O and in program variables of the safety system. Events of this category are typically recorded to investigate cause and effect during a system trip. The event messages are shown in the historical event overview of the CENTUM CS3000 HIS station(s).

MULCOM collects all time stamped events and sorts the events in a single event list according to the time stamps in the event messages. Presentation of the events can be done in three ways:

- In the historical message overview and system alarm overview of the CENTUM CS3000 HIS
- On the local line printer that is connected to the parallel port of MULCOM
- Using the event window of COM SET (connected via Modbus RTU link)

■ Time Distribution and Synchronisation

MULCOM synchronises its own system time with the V-net time. The MULCOM time is distributed to all ProSafe-PLC CCMs via the M-BUS or M-NET. ProSafe-PLC event time stamps can be corrected for differences in CCM clocks depending on projects requirements:

- Default Event Generation: Events are time stamped with the CCM time, sequence of events is not guaranteed.
- Relative Time Stamps: Sequence of events is guaranteed, but event time stamps can deviate from the absolute moment of occurrence. Some ProSafe-PLC I/O channels and additional wiring are required.
- Absolute Time Stamp Correction: Sequence of events is guaranteed and event time stamps show the GMT time of occurrence. Some ProSafe-PLC input channels, additional wiring and GPS receiver(s) are required.
- Use ProSafe-PLC time sync function blocks: No additional wiring or MULCOM time stamp correction is required.

■ Redundancy Options

Redundancy of MULCOM is supported as an Active/Backup redundant configuration. In order to provide redundancy it is necessary to use two MULCOMs, each connected to the V-net and M-BUS/M-NET.

Two separate Y-net networks are needed when ProSafe-SLS is used. Each MULCOM has its own Y-net connection for status and event acquisition.

A MULCOM interlink is used to exchange MULCOM data between the redundant partners.

The CENTUM CS3000 requires specific software for processing the selection of active MULCOM via FCS and HIS. The FCS is connected to each of the MULCOMs via the V-net and continually inspects the diagnostics information that is provided by both MULCOMs. Should the active MULCOM develop a fault and the back-up unit is available, then the back-up unit is switched to active mode.

When OPC or Modbus is applied, the redundancy switchover logic must be implemented in the Host, mostly the DCS or

SCADA system. The switch-over logic must conclude from the diagnostics tags of each MULCOM, which MULCOM will be active and which MULCOM will be back-up.

■ Human Machine interface

The information from the ProSafe safety system and commands to the ProSafe safety system are handled by the HMI package of the CENTUM CS3000.

When OPC is used, any OPC enabled DCS, SCADA, or HMI package can handle the information of the ProSafe safety system.

■ I/O emulation tool

MULCOM can run in emulation mode, all external interfaces (to DCS and to the data acquisition areas) can be emulated using a software tool. MULCOM is fully operational in this mode. This feature allows parallel engineering and testing of the safety system and the DCS application.

■ Remote maintenance

MULCOM can have an optional remote maintenance connection via a modem. This facility allows run-time inspection, file transfer and remote maintenance.

MULCOM data acquisition networks

ProSafe-PLC network

The Critical Control Module Plus (CCM+) is the Central Processing Unit of the ProSafe-PLC. It communicates with MULCOM via M-BUS or M-NET. The MBX module is the intermediate between MULCOM and CCMs when the M-NET is used. M-BUS is used for ProSafe-PLC systems with a limited number of CCMs and limited network distances (figure 4)

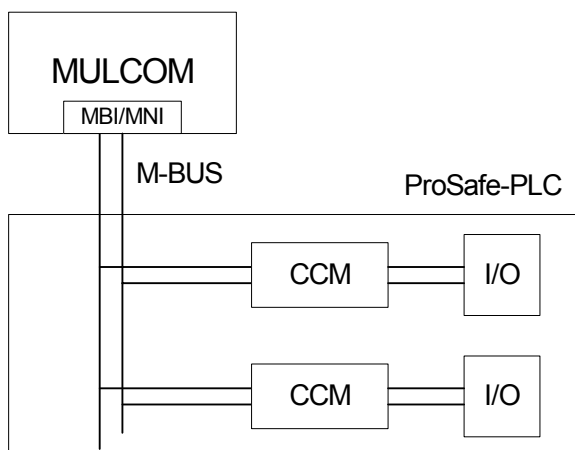

Figure 4 ProSafe-PLC: M-BUS and CCM modules

M-NET supports more ProSafe-PLC racks and longer distances (figure 5). See the appropriate ProSafe-PLC documentation for details.

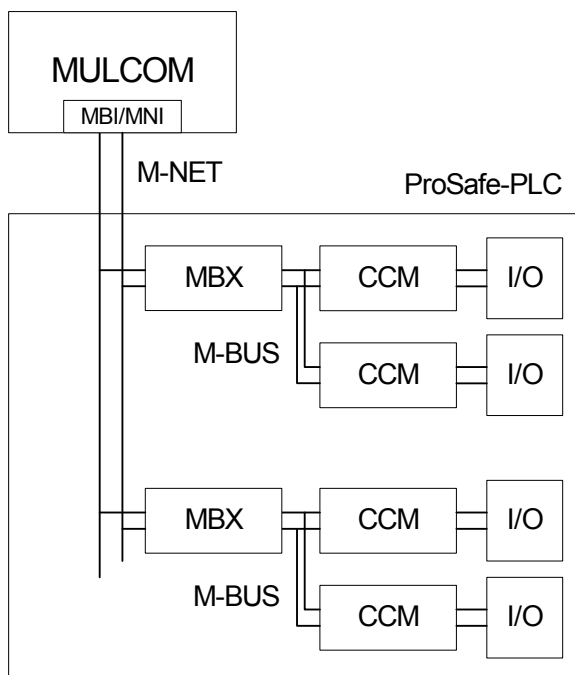

Figure 5 ProSafe-PLC: M-NET, MBX modules and CCM modules

ProSafe-SLS network

The MULCOM Y-net controller CN-956 connects MULCOM to the Y-net. Y-net offers communication modules for connection of digital and analog inputs and digital outputs to the ProSafe-SLS safety system. Y-net also offers communication modules to provide the interface to a matrix panel with push buttons and lamps.

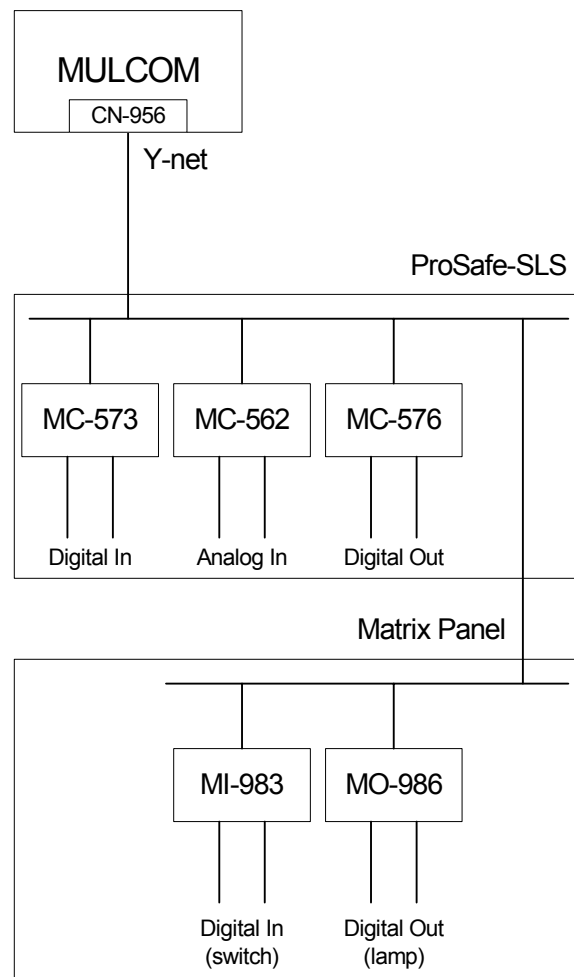

Figure 6 ProSafe-SLS and Matrix Panel modules

Foreign PLC

More than one Modbus slave device can be connected in a multidrop configuration and driven by MULCOM's Modbus master

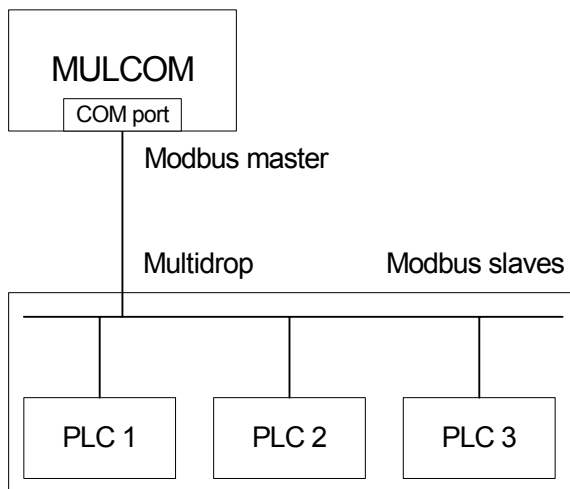

Figure 7 Foreign PLCs connected via MULCOM's Modbus master

Note: Ethernet may be used if the foreign PLCs support Modbus/TCP via Ethernet

■ Prerequisites

- Power supply in the cabinet or bench.
- Presence of existing ProSafe-PLC configuration with operational M-BUS or M-NET network.
- Configured sequence of event function blocks in the ProSafe-PLC programs.
- Version 2.06.00 or higher of the CENTUM CS3000 software and availability of the optional SCS redundancy control software package for the CENTUM CS3000 in case of redundant MULCOM.
- For OPC: TCP/IP connection (10BASE-T or 100BASE-T network) between OPC Client Host Computer and MULCOM.

■ Notes

1. MULCOM will be cabinet-mounted. Display, keyboard and mouse are needed per system location.
2. MULCOM is connected to the V-net using two YCB141 coaxial cables and a V-net Bus Adapter. Either YCB147 (19 inch rack) or YCB149 (simple model) should be ordered. Refer to GS 33Q1B10-01E for V-net spec.
3. For OPC a 10/100 Mbps Ethernet connection (10BASE-T/100BASE-T) is built in the standard MULCOM model.
4. Please consult Sales department at Yokogawa System Center Europe when absolute time stamping is required, GPS is not in the scope of MULCOM ordering.

■ Specifications

Description		Data
General	Identification	MULCOM 2.0
	Hardware platform	CO-960-02/A2
	Operating system	Windows 2000, SP3
	Standard interfaces	2 serial ports, 1 parallel printer port, 2 Ethernet ports 10/100 Mbits/s, 2 USB ports
	Additional interfaces	4 PCI slots for dedicated interface cards
Dimensions	19" housing	483 x 88 x 450 (wxhxd) mm
Power Supply	AC supply (CO-960-02)	100 to 240V auto-range ($\pm 10\%$), 300 Watt, 50/60 Hz
	DC supply (CO-960-A2)	20 to 28V, 10 A
Environmental conditions	Temperature	0 to +50°C, operating
		-20 to +70°C, storage
	Relative humidity	5 - 95%, non condensing
	Shock	15 G peak to peak, 11 ms, non-operating
	Vibration	0.5 Grms, 5-500 Hz each axis, operating
		1.88 Grms, 5-500 Hz each axis, non operating
EMC	Emission, CISPR22 class A	
I/O tags	MULCOM tags	Limited by installed RAM and COM-SET (10.000)
	User tags (configurable via CENTUM CS3000 ENG station)	4000
Communication	V-net	CENTUM CS3000 proprietary network
	Ethernet	Standard W2000 network protocols, OPC, Modbus/TCP
	COM 1-10	RS-232 with Modbus RTU, max. 57600 baud
	M-BUS/M-NET	ProSafe-PLC proprietary bus/network
	Y-net	YEF-SCE proprietary network (RS-485)